

428

Frozen Beverage Freezer

Single Flavour



Features

Vary your menu by offering shakes, smoothies, frozen cocktails, fruit juices, coffees, cappuccino and slush beverages, all served at the desired thickness. Optimised refrigeration system offers efficient operation in an extremely quiet, compact, self-contained freezer.

Freezing Cylinder

One, 6.6 litre.

Mix Hopper

One, 18.9 litre. Refrigerated to maintain mix below 5°C. Approved for dairy and non-dairy products.

Indicator Lights

Add Mix light alerts the operator to add mix. When the Mix Out light flashes, the unit automatically shuts down to prevent damage.

Automatic Consistency Control

A specially designed viscosity control automatically maintains superior product quality. An adjustable control allows the operator to serve a wide variety of frozen beverages at the desired thickness.

Standby

During long no-use periods, the standby feature maintains safe product temperatures in the mix hopper and freezing cylinder.

Freezer Door

Clear, plastic door merchandises product in the making. Dispensing is quick and easy with a simple movement of the draw handle.

Lighted Display

Self-merchandising lighted display backlights the appropriate static decal and downlights the dispensing door. Five decals are included: Frozen Cappuccino, Frozen Drinks, Margaritas, Shakes, and Smoothies. Lighted area is 133.5 mm high by 295.7 mm wide, with 6.3 mm radius corners.

Air Filter

Removable, cleanable and reusable air filter keeps the condenser clean for optimal refrigeration system performance.



Standard 6 & 18



SA2650



Selected 50 Hz. Models

Taylor UK
Soft Serve & Frozen Beverage Equipment

Taylor Company UK

Hillview Otley Ipswich Suffolk IP6 9NP

Tel: +44 (0) 1473 892336

Fax: +44 (0) 1473 892337

www.taylor-company.co.uk

The Taylor Company USA are an:



428 Frozen Beverage Freezer Single Flavour

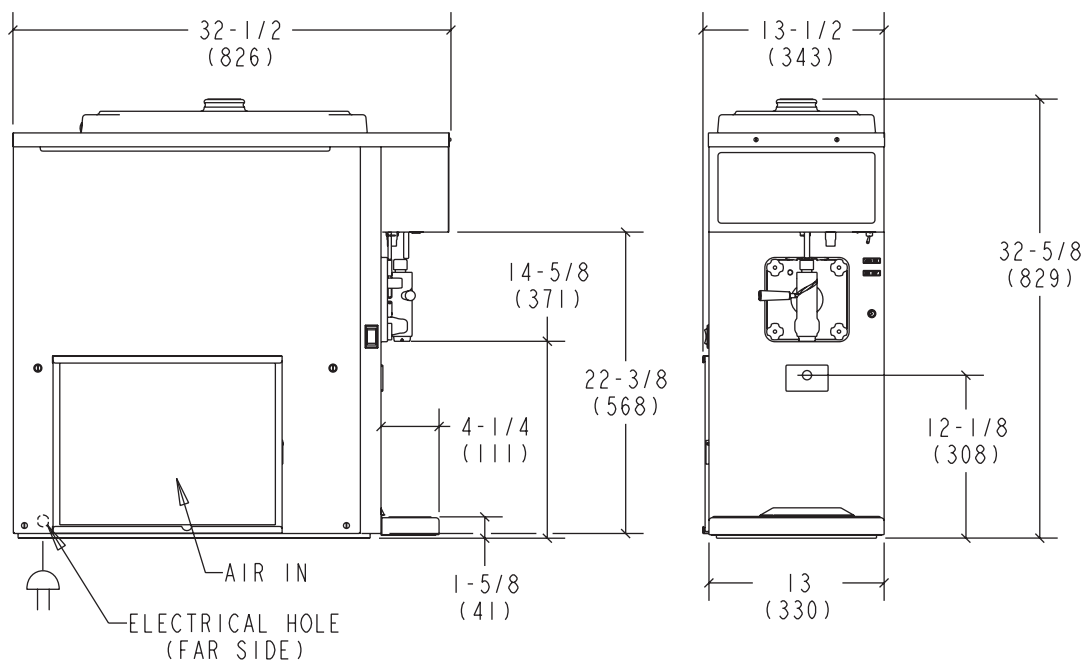

NOTE: FIGURES IN (BRACKETS)
INDICATE MILLIMETRES

Weights	lbs.	kgs.
Net	221	100.2
Crated	264	119.8
	cu. ft.	cu. m.
Volume	22.8	0.64

Dimensions	in.	mm.
Width	13-1/2	343
Depth	32-1/2	826
Height	32-5/8	829
Counter Clearance	*	*

*Designed to rest on a plastic pad directly on counter top.

All machines are air cooled.

Electrical spec

220-240/50/1 2 pole 3 wire Maximum fuse size 13 amp.

Output

Approx 34.1 Litres per hour

Specifications

Electrical

One dedicated 13 amp electrical connection is required. See the electrical chart for the proper electrical requirements. Manufactured to be cord connected.

Refrigeration System

One, approximately 3,600 BTU/hr compressor. R404A.
(BTUs may vary depending on compressor used.)

Beater Motor

One, 1/2 HP.

Air Cooled

Minimum Clearance: 152 mm on both sides. It is recommended to place the rear of the unit against the wall. Minimum air clearances must be met to assure adequate air flow for optimum performance.

Optional Extras

- ▲ Panel Spinner
- ▲ Countertop Spinner

Continuing research results in steady improvements; therefore, these specifications are subject to change without notice.