

QS11

Electric Clamshell Grill



Features

Cook-to-order menu items are served FAST!! With the optional platen lowered, the top and bottom of the product are cooked simultaneously. Foods maintain natural juiciness, and your customers are served food hot off the grill, in less than half the time of standard grills.

Even temperatures across the entire cooking surface assures safe product integrity and fast recovery. Holding cooked food products for busy times is virtually unnecessary, reducing product waste. Multiple grills may be installed side-by-side to increase cooking surface and capacities.

Lower Cooking Surface

One, 12" (30.5 cm) wide, by 24" (61.0 cm) deep cooking zones with three independently controlled heating elements assures even temperatures and quick recovery.

Controls

Programmable microprocessor controls make menu selection simple, including a self-diagnostic feature for serviceability. A clear plastic door protects the controls from splashes or spills, and a separate durable start button is also provided to activate cooking cycle.

Temperature Control

The grill surface temperature may be set from 150 to 400°F (65 to 205°C) and the optional upper platen temperature may be set from 150 to 425°F (65 to 218°C).

Indicator Lights

Lights illuminate when heaters are on.



Optional grooved lower cooking surface and/or grooved upper platen

QS11 Electric Grill

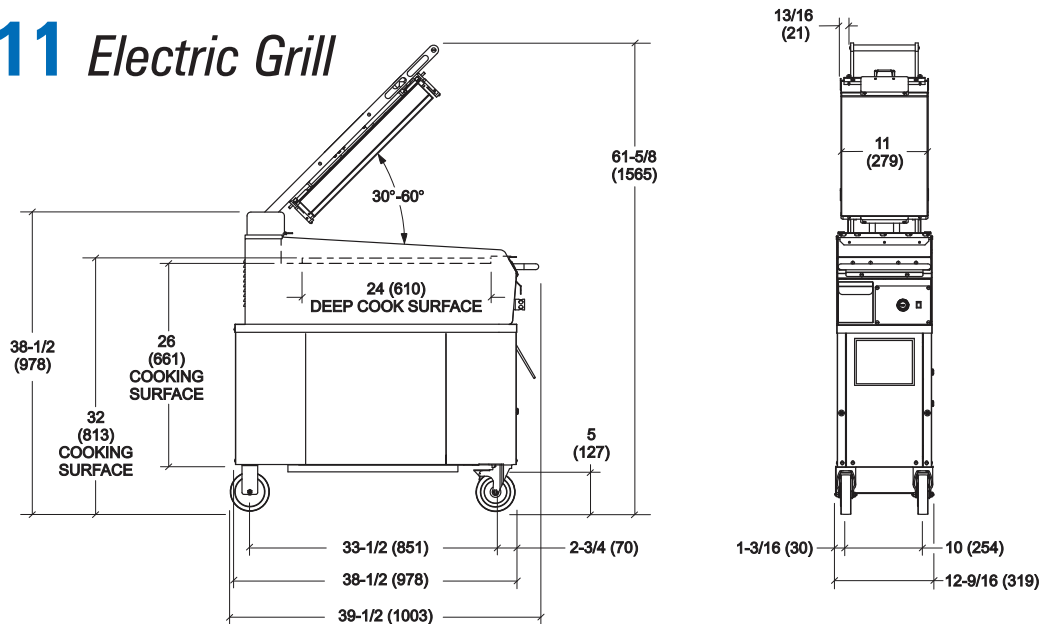

NOTE: FIGURES IN (BRACKETS) INDICATE CENTIMETRES

Weights	lbs.	kgs.
Net	440	199.6
Crated	523	237.2
Volume	cu. ft.	cu. m.
	32.6	0.92

Dimensions	in.	mm.
Width	12-9/16	319
Depth	39-1/2	1003
Height	38-3/8	975
Floor Clearance	5	127

*Mounted on standard casters

All machines are air cooled

Electrical spec

240/50/3 phase Total amps 25.0 Total K.W. 9.6

Specifications

Electrical

One dedicated electrical connection is required. See the Electrical chart for the proper electrical requirements.

Clearance

Grill clearance must be maintained at least 3" (76 mm) from all combustible materials, and 3" (76 mm) of air clearance in the rear.

Optional

- ▲ Grooved lower cooking surface
- ▲ Upper platen, grooved cooking surface
- ▲ Upper Platen, Smooth Cooking Surface
- ▲ Utility box for grill scraper & release sheet wiper

Upper Platen

The upper platen has a cooking surface of 11" X 20" (279 X 508 mm) with three individually controlled heaters. An infinite gap adjustment will accommodate varying product thicknesses from zero to 7/8" (22 mm).

Release Material

Completely covers and protects upper platen surface, prevents product from sticking and minimizes carbon build-up. Attachment method ensures that release material stays in place throughout the day for easy cleaning.

Continuing research results in steady improvements; therefore, these specifications are subject to change without notice.

Taylor UK
Commercial Cooking Equipment

Taylor Company UK

Hillview Otley Ipswich Suffolk IP6 9NP

Tel: +44 (0) 1473 892336

Fax: +44 (0) 1473 892337

www.taylor-company.co.uk