

THE i5 TOUCH™

Ventless* Rapid Cook Oven

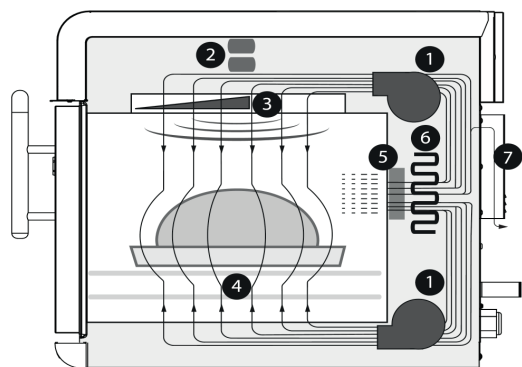

1. Blower motor
2. Top launched microwave
3. Stirred impinged air (top) & microwave
4. Air impingement (bottom)
5. Catalytic converter
6. Impingement heater
7. Vent tube catalyst

ITEM No. _____

Model options:

- THE i5 TOUCH/1A (single phase)
- THE i5 TOUCH/3A (three phase)

Standard equipment:

- 1x Aluminium paddle
- 2x PTFE baskets
- 1x Wire oven rack
- 1x Oven guard protector spray
- 1x Non-caustic oven cleaner
- 12 Months parts and labour warranty

Performance:

- ◆ Utilising TurboChef's patented technology to rapidly cook food without compromising quality, the i5 oven maximises versatility with its large cavity size and ability to cook with most any metal pan up to 1/1 GN.

Exterior Construction:

- ◆ Two-tone stainless steel front, top and sides.
- ◆ 304 stainless steel removable grease collection pan.
- ◆ Ergonomic door handle.
- ◆ Rubber seal for surface mounting.
- ◆ Side hand grips for lifting.
- ◆ 7-inch capacitive touch screen with tempered glass cover.

Interior Construction:

- ◆ 304 stainless steel.
- ◆ Fully welded and insulated cook chamber.
- ◆ Removable rack and lower jetplate.
- ◆ Upper jetplate.

Features:

- ◆ Integral recirculating catalytic converter for UL (KNLZ) listed ventless operation.
- ◆ Independently-controlled dual motors for vertically-recirculated air impingement.
- ◆ Top-launched microwave system.
- ◆ Stirrer to help ensure even distribution of air and microwave.
- ◆ External air filtration.
- ◆ Smart menu system with touch screen interface capable of storing up to 200 recipes.
- ◆ Customisable menu settings via smartcard, USB or manual entry.
- ◆ Flash firmware updates via USB.
- ◆ Single or dual-temperature interface.
- ◆ Vent catalyst to further limit emissions
- ◆ Self-diagnostics for monitoring oven components and performance.

*Ventless cooking operation supported with the exception of food classified as 'raw fatty proteins' such as, but not limited to, bone-in skin-on chicken, raw bacon, raw hamburger etc. Ultimate ventless operation is subject to local authority regulations and landlord permissions.



TaylorUK
Catering Equipment Specialists

Taylor UK (a division of HTG Trading Ltd)
106 Claydon Business Park, Gt. Blakenham,
Ipswich, Suffolk, IP6 0NL, United Kingdom
0800 838 896 - sales@taylor-company.co.uk
www.taylor-company.co.uk

Due to continual research and development, these specifications are subject to change without notification - Jan 2020

THE i5 TOUCH™ - Large Capacity Ventless* Rapid Cook Oven

THE i5 TOUCH™



Large Capacity Ventless* Rapid Cook Oven

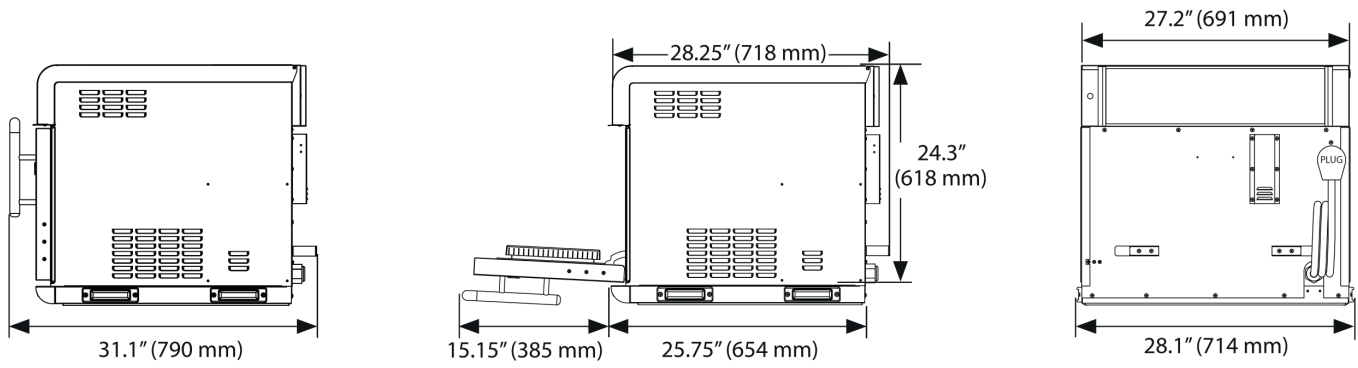

ITEM No. _____

Section view:



Ventilation:

- ◆ Ventless certification
- ◆ EPA 202 test (8 hr):
 - Product: Pepperoni Pizzas
 - Results: 2.80 mg/m³
 - Ventless Requirement: <5.00 mg/m³
- ◆ Internal catalytic filtration to limit smoke, grease, and odour emissions.

THE i5 TOUCH	SINGLE PHASE	THREE PHASE
External OVEN dimensions (WxDxH)	714 x 718 x 618 mm	
Crated dimensions (WxDxH)	813 x 838 x 787 mm	
Net weight / crated weight	125 Kg / 150 Kg	
Cook chamber volume (usable)	62.0 ltr	
Cook chamber dimensions (WxDxH)	610 x 356 x 254 mm	
Wall clearance (sides/rear/top)	51 mm / 0 / 483 mm	
TurboChef ovens are NOT designed for built-in installation.		
Voltage	230v / 50Hz / 1Ph	400v / 50 Hz / 3PH
Max input	10.0 kW	
Circuit breaker (Type D required)	48 amp	24 amp
Isolator socket	62 amp (1P+N+E) 	32 amp (3P+N+E) 

- ◆ A dedicated power supply fitted with a TYPE D circuit breaker is required for all TurboChef installations. Consult with a qualified electrician if in any doubt.
- ◆ Do not block the air inlets and exhaust outlets located on the bottom and rear of the oven. Ovens installed in enclosed areas with limited or no access may invalidate the warranty.

*Ventless cooking operation supported with the exception of food classified as 'raw fatty proteins' such as, but not limited to, bone-in skin-on chicken, raw bacon, raw hamburger etc. Ultimate ventless operation is subject to local authority regulations and landlord permissions.

Improper installation may void the equipment warranty.

THE i5 TOUCH™ – Large Capacity Ventless* Rapid Cook Oven



Taylor UK (a division of HTG Trading Ltd)
 106 Claydon Business Park, Gt. Blakenham,
 Ipswich, Suffolk, IP6 0NL, United Kingdom
0800 838 896 - sales@taylor-company.co.uk
www.taylor-company.co.uk

Due to continual research and development, these specifications are subject to change without notification - Jan 2020