

MULTIVIEW

Multideck display suitable for dairy products



Model RV TN 250



ITEM No. _____

Model options:

(RV - VENTILATED, TN - NORMAL TEMPERATURE - CHILLED)

- MULTIVIEW RV TN 100
- MULTIVIEW RV TN 130
- MULTIVIEW RV TN 190
- MULTIVIEW RV TN 250

Standard equipment:

- LED lighting in upper panel
- Four refrigerated shelves
- External panels - Black (RAL 9005)
- Internal panels - Black (RAL 9005)
- Panoramic side panels
- Automatic condensate evaporator

Optional extras:

- Remote refrigeration installation (call for details)
- Electronic defrost system
- Self rolling night curtain
- LED lighting on every shelf
- Internal plexiglass shelf dividers
- Shelf risers
- Baskets to fit either shelves or the base
- Base shelf tilting kit
- Side pannels with mirrored internal surface
- Internal or external panels in Stainless steel
Custom RAL colours

Features:

- ◆ Wall site display case available either 'plug-in' or with remote condensers with ventilated refrigeration.
- ◆ With a product temperature range of -1 to +5 °C, the Multiview is ideal for the retail display of any fresh produce including dairy.



ENERGY SAVING
LED lights



REFRIGERATION
Ventilated



DEFROST
Off cycle



REFRIGERANT
R404A



INSTALLATION
Plug-In / Remote (optional)



TEMPERATURE
-1 / +5 °C



CLIMATE CLASS
3



Taylor UK (a division of HTG Trading Ltd)
106 Claydon Business Park, Gt. Blakenham,
Ipswich, Suffolk, IP6 0NL, United Kingdom
0800 838 896 - sales@taylor-company.co.uk
www.taylor-company.co.uk

Due to continual research and development, these specifications are subject to change without notification - June 2019

MULTIVIEW - Multideck display suitable for dairy products

MULTIVIEW



Multideck display suitable for dairy products

Section view: (all dimensions in mm)

ITEM No. _____

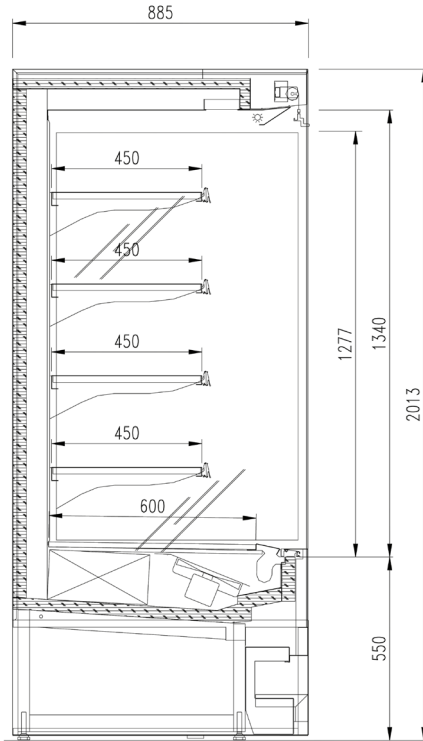

MULTIVIEW - Multideck display suitable for dairy products

MULTIVIEW*	100	130	190	250
External dimensions (LxDxH)	1042 x 885 x 2013 mm	1350 x 885 x 2013 mm	1985 x 885 x 2013 mm	2600 x 885 x 2013 mm
Capacity (gross/net)	870 / 336 ltr	1045 / 422 ltr	1570 / 698 ltr	2098 / 845 ltr
Net weight	215 kg	261 kg	347 kg	412 kg
Refrigeration	Ventilated			
Refrigerant	R404A			
Climate class	3			
Operating conditions	25 °C / 60 %RH			
Product storage temperature	-1 / +5 °C			
Compressor (no. - type)	1 - Hermetic		2 - Hermetic	
Defrost process	Off cycle			
Power supply voltage	230v / 50hz / 1ph			
Electrical input (nominal)	1700 w / 7.3 A	2000 w / 8.6 A	2330 w / 10.1 A	3950 w / 17.1 A
Electrical input (defrost)	770 w / 3.3 A	820 w / 3.6 A	2100 w / 9.1 A	1580 w / 6.8 A



*Data for air cooled units. Remote units available on request.



Taylor UK (a division of HTG Trading Ltd)
 106 Claydon Business Park, Gt. Blakenham,
 Ipswich, Suffolk, IP6 0NL, United Kingdom
0800 838 896 - sales@taylor-company.co.uk
www.taylor-company.co.uk

Due to continual research and development, these specifications are subject to change without notification - June 2019