







ISA DIVA RV H140 220  
(with optional white front panel)

-  **Energy saving** - LED lights + EC fan motor
-  **Defrost** - Reverse cycle
-  **Installation** - Plug-in
-  **Climate class** - 7
-  **Temperature** - -20/+2°C

## Diva

### Professional gelato cabinet

- Ventilated refrigeration with next generation condenser with double ventilated refrigeration system
- One piece body with ecological polyurethane insulation foamed with CO2 - 60mm thick
- Display base and service top in bright stainless steel
- Pillar less tempered glass structure with reduced thickness lateral supports for optimum visibility
- Energy efficient LED lighting
- Closure on the operator side
- Adjustable feet
- Automatic reverse cycle defrosting
- Control board on the operators side with electronic board and digital thermometer inside the tank
- Anti-fog control system
- Temperature control from -20°C to +2°C

#### Standard equipment

Grey side panels

#### Models

DIVA RV H120 120	DIVA RV H140 120
DIVA RV H120 170	DIVA RV H140 170
DIVA RV H120 220	DIVA RV H140 220

Continuing research results in steady improvements; therefore, these specifications are subject to change without notice.

July 2016

# Diva

## Professional gelato cabinet

### Container composition

5 Lt.

(360 x 165 x 120h)

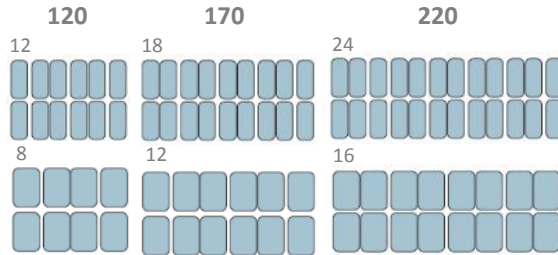

5 Lt.

(360 x 250 x 80h)



### Optional extras

- Cone holder
- Cone holder complete with toppings container
- Scoop wash
- Stainless steel containers
- Ice lolly container - 250 x 360 x 43h mm
- Wheel kit
- RGB LED base lighting

### Optional colours

Side panel

Front panel

Grigio

White

Bisque

Clay

Pearl Gray



### Key

RV - Ventilated refrigeration

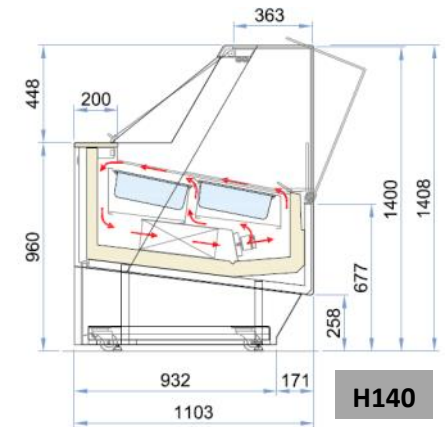
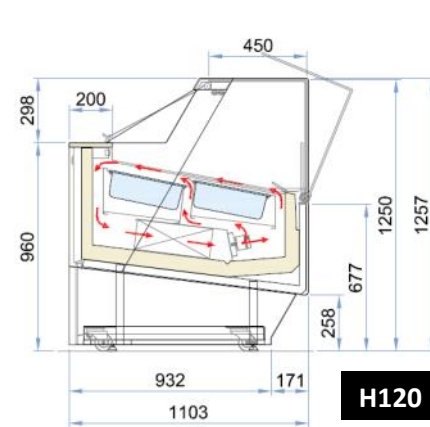

### Technical specification:

		Diva RV 120	Diva RV 170	Diva RV 220
External dimensions (LxDxH)	<b>H120</b> mm	1176 x 1103 x 1257	1671 x 1103 x 1257	2166 x 1103 x 1257
	<b>H140</b> mm	1176 x 1103 x 1408	1671 x 1103 x 1408	2166 x 1103 x 1408
Capacity (gross/net)	<b>H120</b> Lt.	719 / 147	1059 / 216	1399 / 285
	<b>H140</b> Lt.	865 / 147	1273 / 216	1680 / 285
Net weight	<b>H120</b> Kg	300	375	470
	<b>H140</b> Kg	325	385	480
Refrigeration		Ventilated	Ventilated	Ventilated
Refrigerant		R404a	R404a	R404a
Climate class	N°	7	7	7
Operating conditions	°C / % RH	35 / 75	35 / 75	35 / 75
Cabinet capacity range	°C	-20 / +2	-20 / +2	-20 / +2
Product temperature	°C	-16 / -14	-16 / -14	-16 / -14
Compressor (type)		1 Hermetic	2 Hermetic	2 Hermetic
Defrost		Reverse cycle	Reverse cycle	Reverse cycle
Power supply	V / Ph / Hz	230 / 1 / 50	400 / 3 / 50	400 / 3 / 50
Electrical input (standard)	W / A	1240 / 6	1750 / 3	2700 / 4.2
Electrical input (defrost)	W / A	2300 / 11	2950 / 4.9	6300 / 8.5

Continuing research results in steady improvements; therefore, these specifications are subject to change without notice.

July 2016