



# Casadio DT1

## Traditional espresso

### Single group

The Casadio Undici is a compact, elegant, versatile machine that's easy to use, adjust and maintain. Making it the perfect addition to any business looking to add traditional espresso coffee their offer.

#### Construction

The Undici is constructed from a combination of steel and aluminium components for great durability.

#### Controls

The metal mechanical button pads lie flush with the machine panels and LED lights make the operation very user friendly.

#### Thermosyphon system

Undici has a fixed-nozzle thermosyphon system that's adaptable and high performing, guaranteeing excellent results every time.

#### Features include:

- One stainless steel steam wand.
- Each unit is equipped with four dosing selections and one continuous delivery.
- Stainless steel hot water dispenser (metered - selections).
- Graphic display with easy and ergonomic push-button programming.
- Electric cup warmer.



# Casadio DT1 *Traditional espresso*

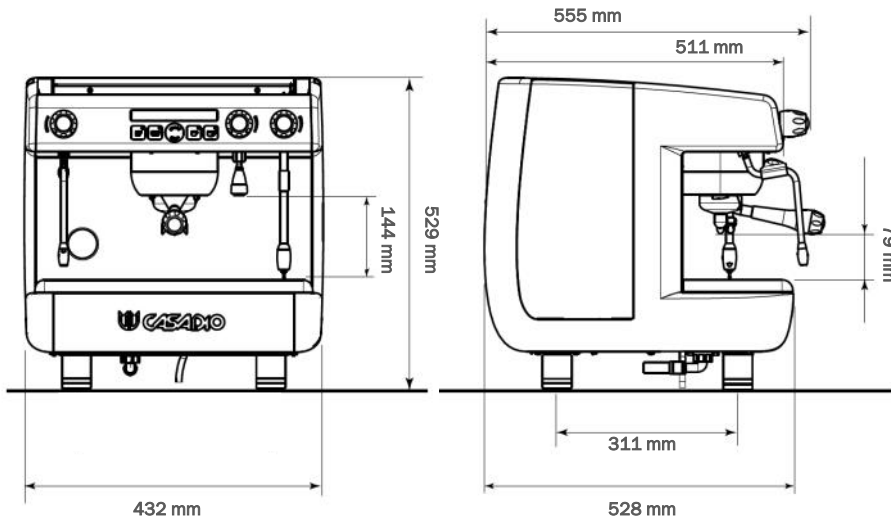

Counter cut-out location:

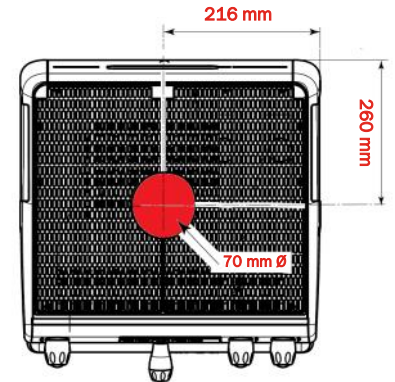

The 70mm Ø hole for services **MUST** be cut prior to delivery and installation.

DIMENSIONS		
Height	20.82"	529 mm
Width	17.01"	432 mm
Depth	21.85"	555 mm
Counter clearance	2"	50 mm
Maximum cup height	4.33"	79 mm
Weight	110 lbs.	50 Kg
<b>Wall air clearance (minimum)*</b>		
Back	1"	25 mm
Sides	6"	150 mm

**Please note** - It is the clients responsibility to install an adequate cold water supply fitted with a suitable water filter, a gravity waste pipe with U-bend located directly below the machine and a dedicated power supply with isolator socket within **one meter** of the machine.

If any counters, worksurfaces or cupboards need cutting or adapting, this must be undertaken by the customer prior to any technical installation by Taylor UK.

\*Access to all sides of the machine will be required to facilitate any service work, any machines installed with limited access or 'boxed in' preventing access may incur additional charges and possibly invalidate any warranty.

ELECTRICAL SPECIFICATION - SINGLE PHASE		
<b>Casadio DT1</b>		
Voltage	220-240 VAC	
Frequency	50 Hz	
Power	2,800 Watts	
Circuit breaker	13 amp	
Plug/Socket	13amp dedicated socket	

WATER CONNECTIONS	
<b>Cold water supply</b>	
Fitting required	15mm pipe with 22mm (3/4") Ø Isolation valve
Supply temperature	13 - 20 °C (55 - 68 °F)
Supply pressure	2-3 Bar ( 29 - 43.5 PSI)
<b>Waste pipe drainage</b>	
Fitting (on machine)	22mm (3/4") Ø
Drainage	38mm (1-1/2") stand pipe with trap located beneath machine/counter
Water filter	3M SGP165