

# FAST CHEF ELITE+

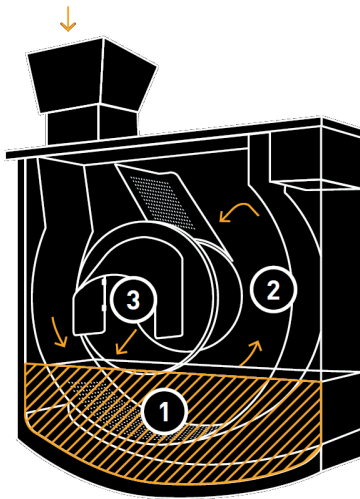

## CARROUSEL - Multi-portion ventless\* fryer



### ECOFRY SYSTEM – The Perfect Cycle

1. **Frying** - protects oil from light, water and oxygen, extending its useful lifespan.
2. **Drained, golden & crispy** - with extraction of evaporated water, oil and excess solid particles.
3. **Extraction** - perfectly cooked product is extracted through the chute into the waiting containers.

ITEM No. \_\_\_\_\_

#### Model options:

- FAST CHEF ELITE+ - CARROUSEL

#### Standard equipment:

- 1x Oil filtering bucket
- 1x Flexible oil drain hose
- 1x Flexible condensate drain hose
- 3x 1/6GN food collection trays
- 1x Operators manual

#### Performance:

- ◆ **Smokeless & odourless** - the FCE+ only releases dry, oil and particle free air back into the environment eliminating the need for expensive extraction hoods. Air from the frying chamber is actively extracted, oil and moisture is condensed and collected, the dry air is then filtered through a panel grease filter before passing through activated carbon to remove odours.
- ◆ **Risk free** - the frying chamber isolates the high temperatures and protects the operator. The enclosed cook chamber limits oxygen levels preventing potential flash fires. The anti-fire system with double sensor and control software cuts power to the heating elements on detection of excessive temperatures.
- ◆ **Clean and easy** - The frying chamber is completely contained preventing oil from dirtying the surrounding internal components.
- ◆ **Sustainable and more profitable** - the unique enclosed frying system protects the cooking oil from UV light and minimises contact with oxygen elongating the oils usable life. SGS\* testing concluded that the FCE+ frying system uses up to 24% less energy and up to 37% less oil compared to conventional open fryers.
- ◆ **Minimal flavour transfer** - the Ecofry technology extracts the moisture away from the products faster sealing the external surface of the foods being cooked. The extracted water is prevented from contaminating the oil reducing flavour transfer from one product to another.

#### Features:

- ◆ 5" touch screen controls with eight programmable cooking times.
- ◆ The FCE+ Carrousel has two cooking modes; **Individual mode** - two portions, up to 300g, can be cooked at the same time with up to four waiting in the carousel. **Large production mode** - up to 500g of product to be cooked at once with up to four additional portions waiting in the carousel.
- ◆ 5.5 litre oil capacity with automatic shut off when oil levels drop below minimum levels prompting the operator to top up the level.
- ◆ Dual temperature sensors ensure accurate heat distribution.
- ◆ The self-contained frying chamber can be completely removed and disassembled for cleaning. 90% of components can be cleaned in a dishwasher.
- ◆ Locking cabinet restricts access to hot areas, operators are protected against accidental burns.
- ◆ Multi-portion catch tray.



**Taylor UK** (a division of HTG Trading Ltd)  
 106 Claydon Business Park, Gt. Blakenham,  
 Ipswich, Suffolk, IP6 0NL, United Kingdom  
**0800 838 896 - sales@taylor-company.co.uk**  
**www.taylor-company.co.uk**

Due to continual research and development, these specifications are subject to change without notification - Jan 2020

FAST CHEF ELITE+ - CARROUSEL - Multi-portion ventless\* fryer

# FAST CHEF ELITE+



## CARROUSEL - Multi-portion ventless\* fryer

ITEM No. \_\_\_\_\_

Section view:

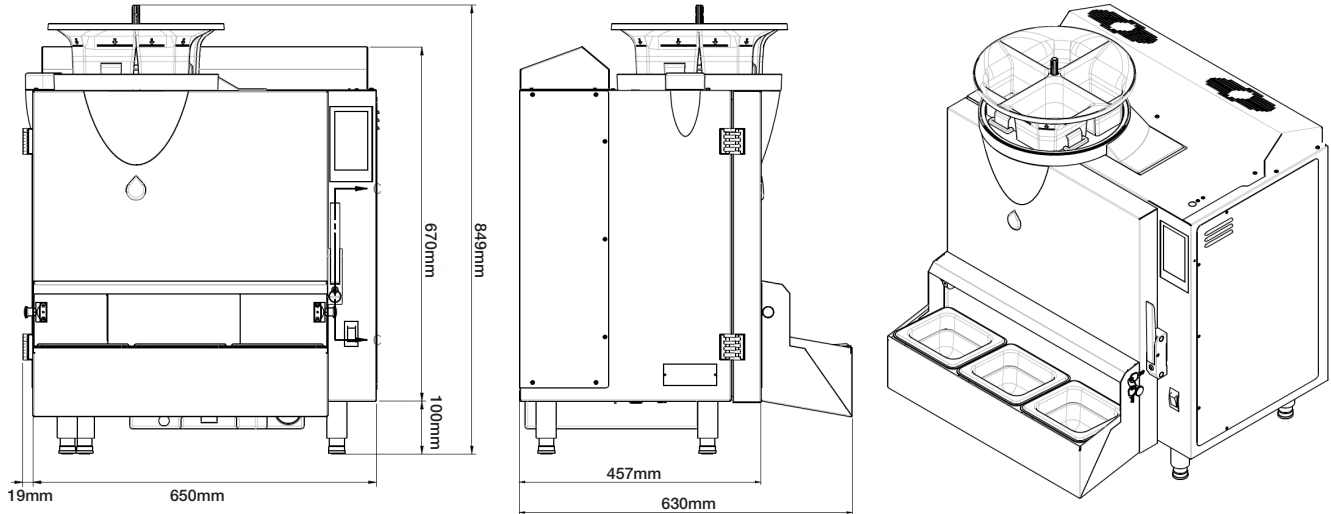

### Cleaning schedule:

- Cooking oil should be drained and filtered every morning before the unit is switched on.
- The frying chamber should be removed, stripped and completely cleaned at least once per week.
- Condensation tank should be drained at least once per week.
- After 8,000\* cook cycles; cylindrical activated carbon filter must be replaced, the panel particulate filter needs to be cleaned and the condensation coil needs to be cleaned and flushed by a qualified technician.

\*Deep cleaning recommended after approximately 8,000 fry cycles or once per year, whichever comes first.

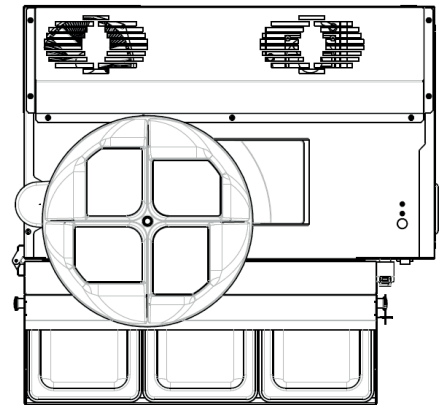

FAST CHEF ELITE+	CARROUSEL
External dimensions (WxDxH)	670 x 630 x 849 mm
Net weight / crated weight	70 Kg / 86 Kg
Wall clearance (sides/top)	150 mm / 300 mm
The FCE+ is <b>NOT</b> intended for built-in installations	
Frying chamber OIL capacity	5.5 ltr
Cooking capacity	2 cooking - 4 hopper
Maximum portion size	300g / 500g
Approximate hourly production**	13 Kg
Voltage	230v / 50Hz / 1Ph
Nominal power	4.6 Kw
Circuit breaker	24 amp
Cable size	3 x 4.0 mm <sup>2</sup>
Isolator socket	32 amp (1P+N+E) 

•To ensure the ventless operation of the Fast Chef Elite+ is maintained, the daily, weekly, monthly and annual cleaning procedures **MUST** be followed and the internal panel grease filter and cylindrical activated carbon filter need to be replaced at the recommended intervals. Failure to do so may invalidate any warranty.

•Fast Chef Elite+ installed in enclosed areas with limited or no access may invalidate the warranty. Avoid installing the Fast Chef Elite+ directly next to heat sources (ovens, grills etc.) or air conditioning outlets. Exhaust air is vented from the top of the unit.

\*Ventless and efficiency certification and testing has been carried out and independently verified by SGS Laboratories. A copy of the report is available on request. Ventless operation is subject to local regulations, check with local authorities and your landlord before installation.-

\*\*Hourly production based on 6mm French fries. oil type, oil age, cooking temperature and product starting temperature will effect cook times and hourly production.

FAST CHEF ELITE+ - CARROUSEL - Multi-portion ventless\* fryer



**Taylor UK** (a division of HTG Trading Ltd)  
106 Claydon Business Park, Gt. Blakenham,  
Ipswich, Suffolk, IP6 0NL, United Kingdom  
**0800 838 896 - sales@taylor-company.co.uk**  
**www.taylor-company.co.uk**

Due to continual research and development, these specifications are subject to change without notification - Jan 2020