

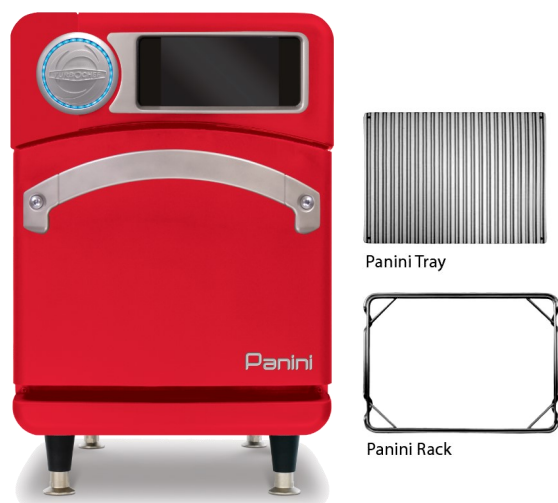

Panini Touch™

Fast toasting



Performance

By combining TurboChef's i-series technology with the Panini tray, restaurants can rapidly toast, heat, grill and bar-mark Panini style sandwiches

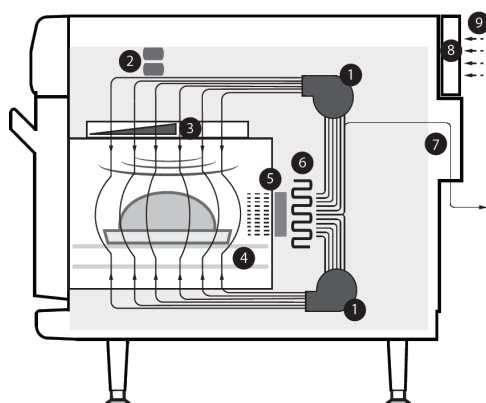

1. Blower Motors
2. Microwave System
3. Stirred Impinged Air (Top) and Microwave
4. Impinged Air (Bottom)
5. Catalytic Converter
6. Impingement Heater
7. Vent Tube Catalyst
8. Air Filter
9. Inlet Air for Cooling Electronic Components

Features

- 7-inch capacitive touch screen with tempered glass cover
- Independently controlled dual motors for vertically-recirculated air impingement
- Top-launched microwave system
- Stirrer to help ensure even distribution of air and microwave
- Integral recirculating catalytic converter for UL listed ventless operation*
- External air filtration
- Vent catalyst to further limit emissions and odours
- LED timer counts down last 30 seconds of cook time
- Smart menu system capable of storing up to 256 recipes
- Flash firmware updates via USB
- Single or dual-temperature interface
- Self-diagnostics for monitoring oven components and performance
- Includes plug and cord - 1.5m long
- Warranty - 1 year parts and labour

Exterior construction

- Powder coated (RAL-3020, Traffic Red), corrosion-resistant steel outer wrap and door
- Die-cast aluminium front panels with matte-chrome accents
- Cool-to-touch exterior; all surfaces below 50°C
- Ergonomic matte-chrome door handle
- 4-inch adjustable legs

Interior construction

- 201/304 stainless steel
- Fully welded and insulated cook chamber
- Removable rack and lower jet plate

Optional feature

- Custom RAL colour exterior (additional cost apply)

Standard accessories supplied with oven

- 1 Aluminium Paddle
- 1 Panini Rack and Tray (i1-3221)
- 1 Bottle Oven Cleaner
- 1 Bottle Oven Guard

*Ventless certification is for all food items except for foods classified as "fatty raw proteins". Such foods include bone-in, skin-on chicken, raw hamburger meat, raw bacon, raw sausages, steaks etc. If cooking these types of foods, it is the customers responsibility to contact their local authorities to ensure compliance with ventilation requirements.

Panini Touch™ Fast toasting

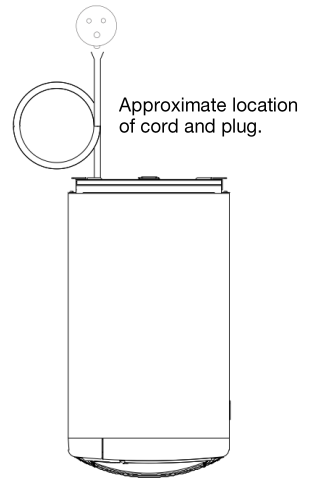
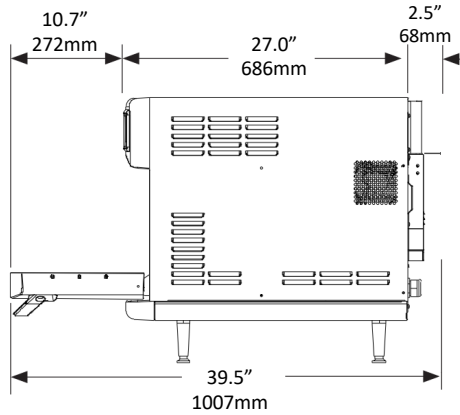
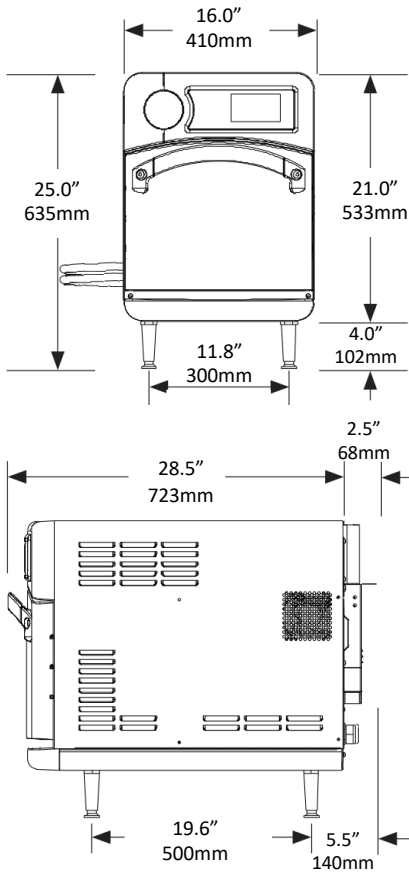

Please Note: Minimum counter depth of **650mm** is required to accommodate the legs. The oven will over hang by approximately 180mm.

DIMENSIONS		
Single units		
Height	25.0"	635 mm
Width	16.0"	406 mm
Depth	29.8"	757 mm
Weight	170 lbs.	77.1 Kg
Cook chamber		
Height	7.2"	183 mm
Width	12.5"	317 mm
Depth	10.5"	266 mm
Volume	0.54 cu.ft	15.4 litres
Wall air clearance* (Oven not intended for built-in installations)		
Top	5"	102 mm
Sides	2"	51 mm

*Ovens installed in enclosed areas with limited or no access may invalidate the warranty.



ELECTRICAL SPECIFICATION - SINGLE PHASE		
Panini Touch i1-9500-421-UK		
Voltage	230 VAC	
Frequency	50 Hz	
Circuit breaker	32amp - D-rated	
Plug/socket	IEC 309, 32amp 3 -pin socket	
Max input	6200 watts	
ELECTRICAL SPECIFICATION - THREE PHASE		
Panini Touch i1-9500-423-EW		
Voltage	380 - 415 VAC	
Frequency	50 Hz	
Circuit breaker	20amp - D-rated	
Plug/socket	IEC 309, 32amp 5 -pin socket	
Max input	6200 watts	

A type D circuit breaker is required for **ALL** TurboChef installations.

Continuing research results in steady improvements; therefore, these specifications are subject to change without notice.

February 2019

Taylor UK
Commercial Cooking Equipment

Taylor UK
 106 Claydon Business Park, Ipswich, Suffolk, IP6 0NL
 Tel: +44 (0) 1473 350046
 Fax: +44 (0) 1473 350001
www.taylor-company.co.uk
sales@taylor-company.co.uk