

IL CARRETTINO

CARAPINE Pozzetti gelato cart



Model IL CARRETTINO CARAPINE - BROWN



ITEM No. _____

Model options:

IL CARRETTINO CARAPINE - BROWN

Standard equipment:

- Straight glass
- Work top - Bright stainless steel
- Body colour - Brown (with graphics)
- Built-in scoop washer
- Water tap
- Water tanks
- Carapine lids (8)
- Two wheels and one pivoting castor
- Sun canopy (solid beige)

Optional extras:

- 7 Lt 200 x 250h mm carapine container
- Choice of body colours; White, Black or Yellow

PLEASE NOTE: The IL Carrettino is designed for fixed installations and is NOT a mobile cart.

Features:

- ◆ Pozzetti gelato trolley with ventilated refrigeration system, finned evaporator and hot gas automatic defrost.
- ◆ Climate friendly R290 Propane refrigerant.
- ◆ Body structure with ecological polyurethane insulation (HCFC & HFC free) foamed with CO2.
- ◆ Internal tank and service top finished in bright stainless steel.
- ◆ External tank in carbon steel with graphics and external base finished in painted sheet steel.
- ◆ Straight tempered glass upper structure.
- ◆ Sun canopy with side supports in tubular stainless steel.
- ◆ Hermetic condensing unit with electronic control board.
- ◆ Main structure in powder coated carbon steel.
- ◆ Two main wheels with one pivoting wheel.
- ◆ Handle in tubular stainless steel for easier handling.



ENERGY SAVING
LED lights



REFRIGERATION
Ventilated



DEFROST
Hot gas



REFRIGERANT
R290



INSTALLATION
Plug-In



TEMPERATURE
-16 / -14 °C



CLIMATE CLASS
4



Sistema di Qualità
ISO 9001
Cert. CISQ/CSQ 9130.TAIF



Sistema di Qualità
ISO 14001
Cert. CIS ECO ISO 9191.ISA3



ISO 14064



Taylor UK (a division of HTG Trading Ltd)
106 Claydon Business Park, Gt. Blakenham,
Ipswich, Suffolk, IP6 0NL, United Kingdom
0800 838 896 - sales@taylor-company.co.uk
www.taylor-company.co.uk

Due to continual research and development, these specifications are subject to change without notification.

March 2021

IL CARRETTINO



CARAPINE Pozzetti gelato cart

Section view: (all dimensions in mm)

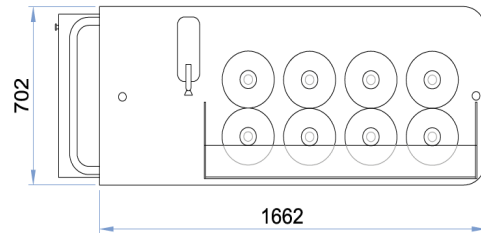
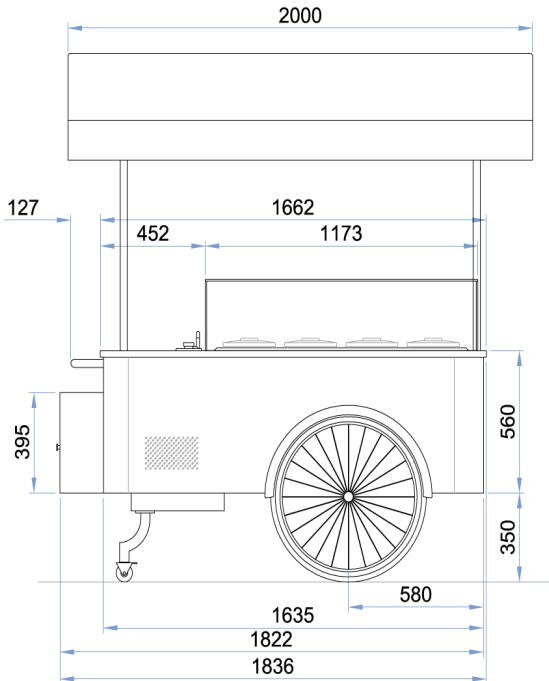

ITEM No. _____

Carapine configuration:



7 Lt Carapine
200 x 250(h) mm

Display
8

Model - ALL

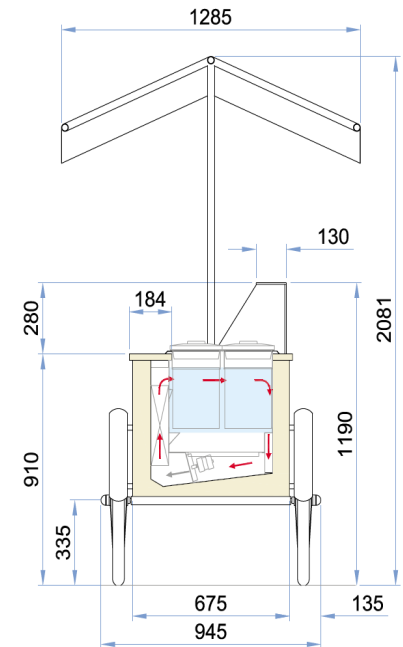

IL CARRETTINO*	CARAPINE
External dimensions (LxDxH)	2000 x 1285 x 2081 mm
Capacity (gross/net)	260 / 104 Lt
Net weight	205 kg
Refrigeration	Ventilated
Refrigerant	R290
Climate class	4
Operating conditions	30 °C / 55 %RH
Product storage temperature	-16 / -14 °C
Compressor (no. - type)	1 - Hermetic
Defrost process	Hot gas
Power supply voltage	230v / 50hz / 1ph
Electrical input (nominal)	470 w / 2.2 A
Electrical input (defrost)	750 w / 3.5 A

IL CARRETTINO CARAPINE - Pozzetti gelato display trolley - 8 flavour



Taylor UK (a division of HTG Trading Ltd)
106 Claydon Business Park, Gt. Blakenham,
Ipswich, Suffolk, IP6 0NL, United Kingdom
0800 838 896 - sales@taylor-company.co.uk
www.taylor-company.co.uk

Due to continual research and development, these specifications are subject to change without notification.

*Data for air cooled units. Water cooled and remote installations are available on request.