

CRISTAL TOWER 75



Pastry showcase with all round visibility



Model 75 RV TN



Model 75 RV TN with optional white panels

ITEM No. _____

Model options:

- (RV - VENTILATED, TN - NORMAL TEMPERATURE - CHILLED)
- CRISTAL TOWER 75 RV TN
- CRISTAL TOWER 75 RV TN RG (rotating shelves)
- (RV - VENTILATED, TB/TN - DUAL TEMPERATURE - CHILLED/FROZEN)
- CRISTAL TOWER 75 RV TB/TN
- CRISTAL TOWER 75 RV TB/TN RG (rotating shelves)
- (RS - STATIC, TB - LOW TEMPERATURE - FROZEN)
- CRISTAL TOWER 75 RS TB
- (RV - VENTILATED, CH - CHOCOLATE ONLY)
- CRISTAL TOWER 75 RV CH

Standard equipment:

- Cool white LED lighting 5700 K°
- Five shelves
- Front panel - Black (RAL 9005)
- Side panels - Black (RAL 9005)
- Anti-fog door film
- Swivel castors with brake
- Manual handle opening door

Optional extras:

- Tray for cup cakes (420 x 140 x 30H mm)
- Tray for ice lollies (250 x 360 x 43H mm)
- Additional glass shelves (580 x 465 mm)
- Touch free door opening
- Front and side panels in White (RAL9003)

Features:

- ◆ Display space completely in glass for maximum product visibility on all four sides. Front control panel with optional Touch Pad system with electronic control with alarms high/low temperature, open door/On/Off touch main switch.
- ◆ The refrigeration system allows excellent temperature maintenance also in the case of many door openings.
- ◆ One piece structure with polyurethane ecological insulation (HCFC & HFC free) foamed with CO2 with low environmental impact.
- ◆ Completely replaceable tempered glass structure. Tempered double glass door screen in the line with profile. Manual handle opening on the standard version with self-closing door.
- ◆ Complete access to the condensing unit from the front and from the rear thanks to the easy removal of the lower panels.



ENERGY SAVING
LED lights + EC fan motor



REFRIGERATION
Ventilated (TN)
Static (TB)



DEFROST
RV TB/TN - Hot gas
RV TN - Off cycle
RS TB - Manual



REFRIGERANT
R290



INSTALLATION
Plug-In



TEMPERATURE
-15 / -18 °C - TB
+1 / +10 °C - TN
+14 / +16 °C - CH



CLIMATE CLASS
4



ENERGY RATING
B - RV TN
C - RV TB



Sistema di Qualità
ISO 9001
Cert. CISQ/CSQ 9130.TAIF



Sistema di Qualità
ISO 14001
Cert. CIS ECO ISO 9191.ISA3

aria ISO 14064



Taylor UK
Catering Equipment Specialists

Taylor UK (a division of HTG Trading Ltd)
106 Claydon Business Park, Gt. Blakenham,
Ipswich, Suffolk, IP6 0NL, United Kingdom
0800 838 896 - sales@taylor-company.co.uk
www.taylor-company.co.uk

Due to continual research and development, these specifications are subject to change without notification.

March 2021

CRISTAL TOWER 75 - Pastry showcase with all round visibility - chilled, frozen or chocolate

CRISTAL TOWER 75



Pastry showcase with all round visibility

Section view: (all dimensions in mm)

ITEM No. _____

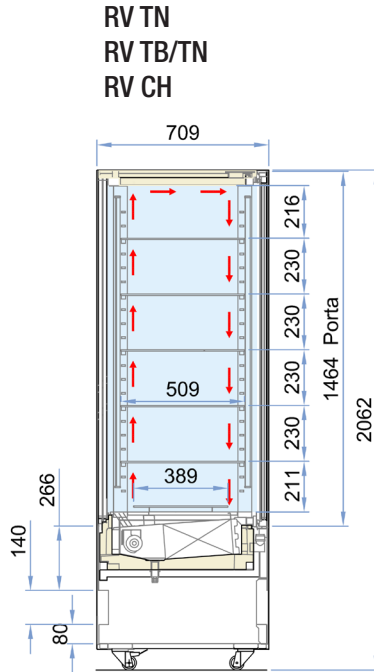
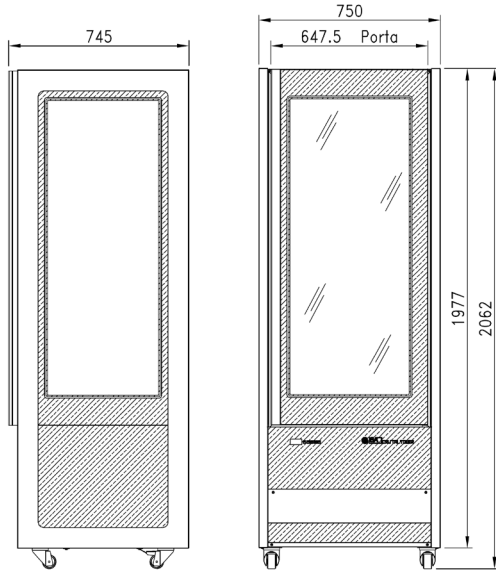

Shelves are adjustable in RV models.
RG versions have circular rotating shelves.

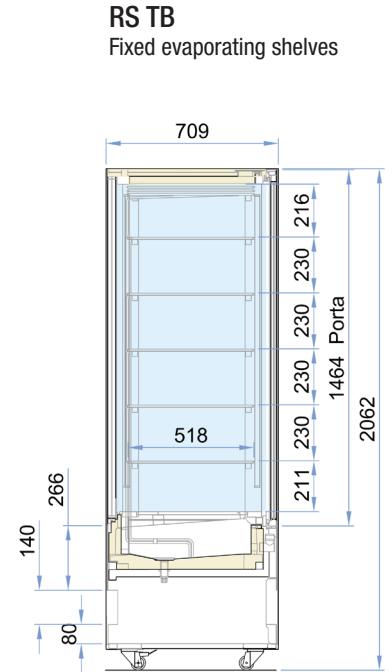

Shelves are fixed in RS model.

CRISTAL TOWER 75

Height	Length	Model type	Display area m ²	Temp class	Recomm. temp °C	Energy class	Energy Efficiency Index	Annual Energy kWh/A
H206 GELATO	75	IVF4	2.31	L1	-20 °C	C (R290)	34.66	7,256
H206 PASTRY	75	IVC4	2.31	M1	+2 °C	B (R290)	12.96	1,805

Configuration: air cooled plug-in unit (R290) double glass doors with automatic opening, LED lighting

CRISTAL TOWER 75*

	RV TN	RV TN RG	RV TB/TN	RV TB/TN RG	RS TB	RV CH
	CHILLED ONLY		CHILLED or FROZEN		FROZEN ONLY	CHOCOLATE ONLY
External dimensions (LxDxH)	750 x 745 x 2062 mm					
Shelf dimensions	580 x 465 mm	∅ 480 (rotating)	580 x 465 mm	∅ 480 mm (rotating)	580 x 498 mm	580 x 465 mm
Capacity (gross/net)	383 / 565 Lt					
Net weight	288 kg					
Refrigeration	Ventilated			Static		Ventilated
Refrigerant	R290					
Climate class	4					
Operating conditions	30 °C / 55 %RH					
Product storage temperature	+1 / +10 °C		-18 / +10 °C		-15 / -18 °C	+14 / +16 °C
Compressor (no. - type)	1 - Hermetic					
Defrost process	Off cycle		Hot gas		Manual	Off cycle
Power supply voltage	230v / 50hz / 1ph					
Electrical input (nominal)	470 w / 3.1 A		1040 w / 5.1 A		820 w / 4.3A	800 w / 3.8 A
Electrical input (defrost)	50 w / 0.4 A		1500 w / 7.1 A		N/A	400 w / 3.2 A



Taylor UK (a division of HTG Trading Ltd)
 106 Claydon Business Park, Gt. Blakenham,
 Ipswich, Suffolk, IP6 0NL, United Kingdom
0800 838 896 - sales@taylor-company.co.uk
www.taylor-company.co.uk

Due to continual research and development, these specifications are subject to change without notification.

*Data for air cooled units. Water cooled and remote installations are available on request.

CRISTAL TOWER 75 - Pastry showcase with all round visibility - chilled, frozen or chocolate

CRISTAL TOWER 75LH



Pastry showcase with all round visibility



Model 75LH RV TN



Model 75LH RV TN with optional white panels

ITEM No. _____

Model options:

(RV - VENTILATED, TN - NORMAL TEMPERATURE - CHILLED)

CRISTAL TOWER 75LH RV TN

(RV - VENTILATED, TB/TN - DUAL TEMPERATURE - CHILLED/FROZEN)

CRISTAL TOWER 75LH RV TB/TN

(RS - STATIC, TB - LOW TEMPERATURE - FROZEN)

CRISTAL TOWER 75LH RS TB

Standard equipment:

- Cool white LED lighting 5700 K°
- Four shelves
- Front panel - Black (RAL 9005)
- Side panels - Black (RAL 9005)
- Anti-fog door film
- Swivel castors with brake
- Manual handle opening door

Optional extras:

- Tray for cup cakes (420 x 140 x 30H mm)
- Tray for ice lollies (250 x 360 x 43H mm)
- Additional glass shelves (580 x 465 mm)
- Touch free door opening
- Front and side panels in White (RAL9003)

Features:

- ◆ Display space completely in glass for maximum product visibility on all four sides. Front control panel with optional Touch Pad system with electronic control with alarms high/low temperature, open door/On/Off touch main switch.
- ◆ The refrigeration system allows excellent temperature maintenance also in the case of many door openings.
- ◆ One piece structure with polyurethane ecological insulation (HCFC & HFC free) foamed with CO2 with low environmental impact.
- ◆ Completely replaceable tempered glass structure. Tempered double glass door screen in the line with profile. Manual handle opening on the standard version with self-closing door.
- ◆ Complete access to the condensing unit from the front and from the rear thanks to the easy removal of the lower panels.



ENERGY SAVING
LED lights + EC fan motor



REFRIGERATION
Ventilated (TN)
Static (TB)



DEFROST
RV TB/TN - Hot gas
RV TN - Off cycle
RS TB - Manual



REFRIGERANT
R290



INSTALLATION
Plug-In



TEMPERATURE
-15 / -18 °C - TB
+1 / +10 °C - TN



CLIMATE CLASS
4



ENERGY RATING
B - RV TN
C - RV TB



Sistema di Qualità
ISO 9001
Cert. CISQ/CSQ 9130.TAIF



Sistema di Qualità
ISO 14001
Cert. CIS ECO ISO 9191.ISA3

aria ISO 14064



Taylor UK (a division of HTG Trading Ltd)
106 Claydon Business Park, Gt. Blakenham,
Ipswich, Suffolk, IP6 0NL, United Kingdom
0800 838 896 - sales@taylor-company.co.uk
www.taylor-company.co.uk

Due to continual research and development, these specifications are subject to change without notification.

March 2021

CRISTAL TOWER 75LH - Pastry showcase with all round visibility - chilled or frozen

CRISTAL TOWER 75LH



Pastry showcase with all round visibility

Section view: (all dimensions in mm)

ITEM No. _____

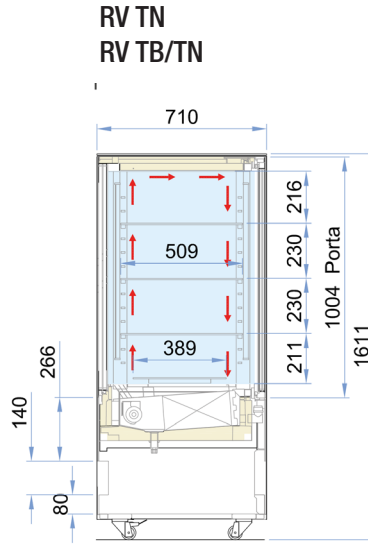
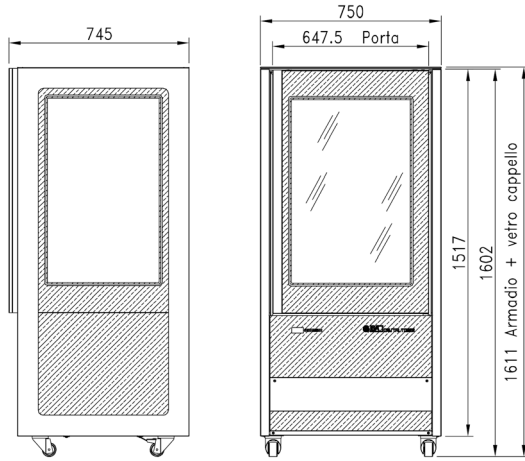

Shelves are adjustable in RV models.

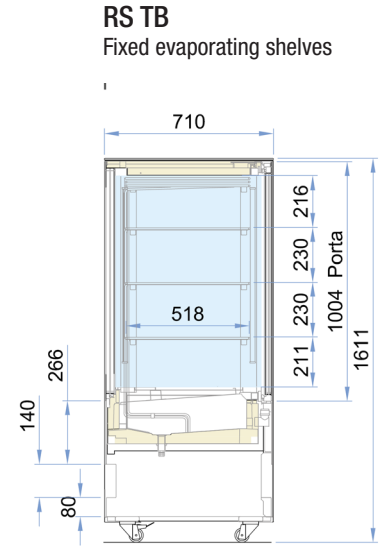

Shelves are fixed in RS model.

CRISTAL TOWER 75LH		Model type	Display area m ²	Temp class	Recomm. temp °C	Energy class	Energy Efficiency Index	Annual Energy kWh/A
Height	Length							
H160 GELATO	75	IVF4	1.46	L1	-20 °C	C (R290)	35.96	5,151
H160 PASTRY	75	IVC4	1.46	M1	+2 °C	B (R290)	13.66	1,605

Configuration: air cooled plug-in unit (R290) double glass doors with automatic opening, LED lighting

CRISTAL TOWER 75LH*	RV TN	RV TB/TN	RS TB
	CHILLED ONLY	CHILLED or FROZEN	FROZEN ONLY
External dimensions (LxDxH)	750 x 745 x 1611 mm		
Shelf dimensions	580 x 465 mm		
Capacity (gross/net)	243 / 372 Lt		
Net weight	195 kg		
Refrigeration	Ventilated		Static
Refrigerant	R290		
Climate class	4		
Operating conditions	30 °C / 55 %RH		
Product storage temperature	+1 / +10 °C	-18 / +10 °C	-15 / -18 °C
Compressor (no. - type)	1 - Hermetic		
Defrost process	Off cycle	Hot gas	Manual
Power supply voltage	230v / 50hz / 1ph		
Electrical input (nominal)	450 w / 3.0 A	1000 w / 5.1 A	370 w / 2.2 A
Electrical input (defrost)	40 w / 0.4 A	1450 w / 7.0 A	N/A

Taylor UK (a division of HTG Trading Ltd)
 106 Claydon Business Park, Gt. Blakenham,
 Ipswich, Suffolk, IP6 0NL, United Kingdom
0800 838 896 - sales@taylor-company.co.uk
www.taylor-company.co.uk

Due to continual research and development, these specifications are subject to change without notification.

CRISTAL TOWER 75LH - Pastry showcase with all round visibility - chilled or frozen

*Data for air cooled units. Water cooled and remote installations are available on request.

CRISTAL TOWER 93



Pastry showcase with all round visibility



Model 93 RV TN



Model 93 RV TN with optional white panels

ITEM No. _____

Model options:

(RV - VENTILATED, TN - NORMAL TEMPERATURE - CHILLED)

CRISTAL TOWER 93 RV TN

(RV - VENTILATED, TB/TN - DUAL TEMPERATURE - CHILLED/FROZEN)

CRISTAL TOWER 93 RV TB/TN

(RS - STATIC, TB - LOW TEMPERATURE - FROZEN)

CRISTAL TOWER 93 RS TB

(RV - VENTILATED, CH - CHOCOLATE ONLY)

CRISTAL TOWER 93 RV CH

Standard equipment:

Cool white LED lighting 5700 K°

Five shelves

Front panel - Black (RAL 9005)

Side panels - Black (RAL 9005)

Anti-fog door film

Swivel castors with brake

Manual handle opening door

Optional extras:

Tray for cup cakes (420 x 140 x 30H mm)

Tray for ice lollies (250 x 360 x 43H mm)

Additional glass shelves (580 x 465 mm)

Touch free door opening

Front and side panels in White (RAL9003)

Features:

- ◆ Display space completely in glass for maximum product visibility on all four sides. Front control panel with optional Touch Pad system with electronic control with alarms high/low temperature, open door/On/Off touch main switch.
- ◆ The refrigeration system allows excellent temperature maintenance also in the case of many door openings.
- ◆ One piece structure with polyurethane ecological insulation (HCFC & HFC free) foamed with CO2 with low environmental impact.
- ◆ Completely replaceable tempered glass structure. Tempered double glass door screen in the line with profile. Manual handle opening on the standard version with self-closing door.
- ◆ Complete access to the condensing unit from the front and from the rear thanks to the easy removal of the lower panels.



ENERGY SAVING
LED lights + EC fan motor



REFRIGERATION
Ventilated (TN)
Static (TB)



DEFROST
RV TB/TN - Hot gas
RV TN - Off cycle
RS TB - Manual



REFRIGERANT
R290



INSTALLATION
Plug-In



TEMPERATURE
-15 / -18 °C - TB
+1 / +10 °C - TN
+14 / +16 °C - CH



CLIMATE CLASS
4



ENERGY RATING
B - RV TN
C - RV TB



Sistema di Qualità
ISO 9001
Cert. CISQ/CSQ 9130.TAIF



Sistema di Qualità
ISO 14001
Cert. CIS ECO ISO 9191.ISA3



Taylor UK (a division of HTG Trading Ltd)
106 Claydon Business Park, Gt. Blakenham,
Ipswich, Suffolk, IP6 0NL, United Kingdom
0800 838 896 - sales@taylor-company.co.uk
www.taylor-company.co.uk

Due to continual research and development, these specifications are subject to change without notification.

March 2021

CRISTAL TOWER 93 - Pastry showcase with all round visibility - chilled, frozen or chocolate

CRISTAL TOWER 93



Pastry showcase with all round visibility

Section view: (all dimensions in mm)

ITEM No. _____

CRISTAL TOWER 93 - Pastry showcase with all round visibility - chilled, frozen or chocolate

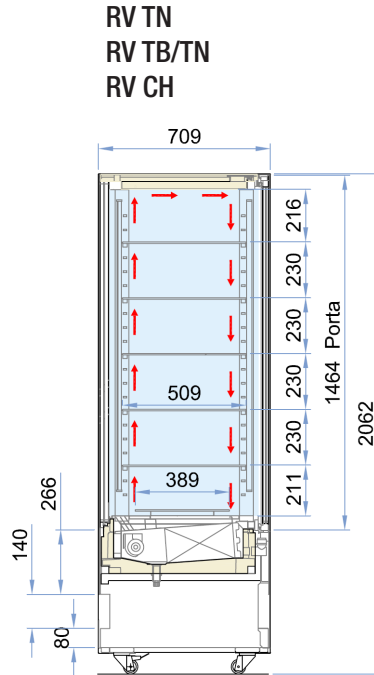
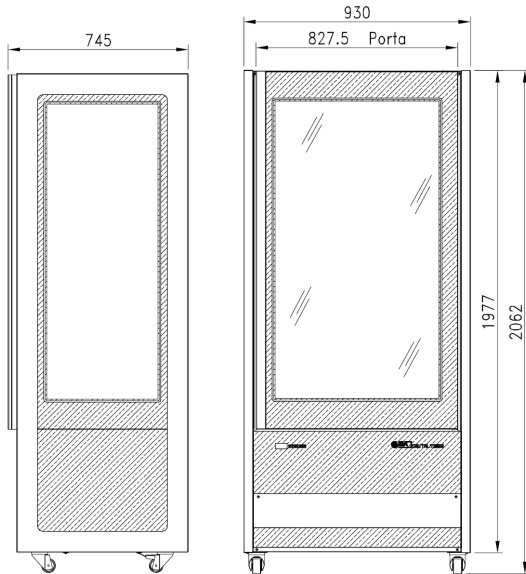

Shelves are adjustable in RV models.

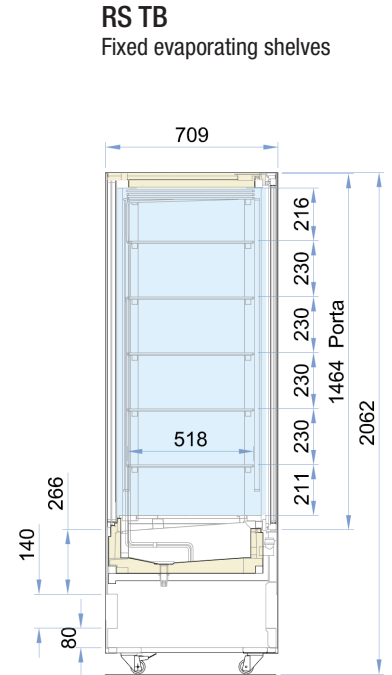

Shelves are fixed in RS model.

CRISTAL TOWER 93		Model type	Display area m ²	Temp class	Recomm. temp °C	Energy class	Energy Efficiency Index	Annual Energy kWh/A
Height	Length							
H206 GELATO	93	IVF4	2.75	L1	-20 °C	C (R290)	35.37	8,609
H206 PASTRY	93	IVC4	2.75	M1	+2 °C	B (R290)	16.69	2,632

Configuration: air cooled plug-in unit (R290) double glass doors with automatic opening, LED lighting

CRISTAL TOWER 93*	RV TN	RV TB/TN	RS TB	RV CH
	CHILLED ONLY	CHILLED or FROZEN	FROZEN ONLY	CHOCOLATE ONLY
External dimensions (LxDxH)	930 x 745 x 2062 mm			
Shelf dimensions	780 x 465 mm	780 x 465 mm	780 x 498 mm	780 x 465 mm
Capacity (gross/net)	494 / 718 ltr			
Net weight	310 Kg			
Refrigeration	Ventilated		Static	Ventilated
Refrigerant	R290			
Climate class	4			
Operating conditions	30 °C / 55 %RH			
Product storage temperature	+1 / +10 °C	-18 / +10 °C	-15 / -18 °C	+14 / +16 °C
Compressor (no. - type)	1 - Hermetic			
Defrost process	Off cycle	Hot gas	Manual	Off cycle
Power supply voltage	230v / 50hz / 1ph			
Electrical input (nominal)	580 w / 3.1 A	1250 w / 5.8 A	1200 w / 6.0 A	800 w / 3.8 A
Electrical input (defrost)	160 w / 0.8 A	2030 w / 9.0 A	N/A	4000 w / 3.2 A

Taylor UK (a division of HTG Trading Ltd)
 106 Claydon Business Park, Gt. Blakenham,
 Ipswich, Suffolk, IP6 0NL, United Kingdom
0800 838 896 - sales@taylor-company.co.uk
www.taylor-company.co.uk

Due to continual research and development, these specifications are subject to change without notification.

*Data for air cooled units. Water cooled and remote installations are available on request.

CRISTAL TOWER 93LH



Low height pastry showcase with all round visibility



Model 93LH RV TN with optional additional shelf



Model 93LH RV TN with optional white panels and additional shelf

ITEM No. _____

Model options:

(RV - VENTILATED, TN - NORMAL TEMPERATURE - CHILLED)

CRISTAL TOWER 93LH RV TN

(RV - VENTILATED, TB/TN - DUAL TEMPERATURE - CHILLED/FROZEN)

CRISTAL TOWER 93LH RV TB/TN

(RS - STATIC, TB - LOW TEMPERATURE - FROZEN)

CRISTAL TOWER 93LH RS TB

Standard equipment:

Cool white LED lighting 5700 K°

Three shelves

Front panel - Black RAL 9005

Side panels - Black RAL 9005

Anti-fog door film

Swivel castors with brake

Manual handle opening door

Optional extras:

Tray for cup cakes (420 x 140 x 30H mm)

Tray for ice lollies (250 x 360 x 43H mm)

Additional glass shelves (580 x 465 mm)

Touch free door opening

Front and side panels in White (RAL9003)

Features:

- ◆ Display space completely in glass for maximum product visibility on all four sides. Front control panel with optional Touch Pad system with electronic control with alarms high/low temperature, open door/On/Off touch main switch.
- ◆ The refrigeration system allows excellent temperature maintenance also in the case of many door openings.
- ◆ One piece structure with polyurethane ecological insulation (HCFC & HFC free) foamed with CO2 with low environmental impact.
- ◆ Completely replaceable tempered glass structure. Tempered double glass door screen in the line with profile. Manual handle opening on the standard version with self-closing door.
- ◆ Complete access to the condensing unit from the front and from the rear thanks to the easy removal of the lower panels.



ENERGY SAVING
LED lights + EC fan motor



REFRIGERATION
Ventilated (TN)
Static (TB)



DEFROST
RV TB/TN - Hot gas
RV TN - Off cycle
RS TB - Manual



REFRIGERANT
R290



INSTALLATION
Plug-In



TEMPERATURE
-15 / -18 °C - TB
+1 / +10 °C - TN



CLIMATE CLASS
4



ENERGY RATING
B - RV TN
C - RV TB



Sistema di Qualità
ISO 9001
Cert. CISQ/CSQ 9130.TAIF



Sistema di Qualità
ISO 14001
Cert. CIS ECO ISO 9191.ISA3

aria ISO 14064



Taylor UK
Catering Equipment Specialists

Taylor UK (a division of HTG Trading Ltd)
106 Claydon Business Park, Gt. Blakenham,
Ipswich, Suffolk, IP6 0NL, United Kingdom
0800 838 896 - sales@taylor-company.co.uk
www.taylor-company.co.uk

Due to continual research and development, these specifications are subject to change without notification.

March 2021

CRISTAL TOWER 93LH - Low height pastry showcase - chilled or frozen

CRISTAL TOWER 93LH



Low height pastry showcase with all round visibility

Section view: (all dimensions in mm)

ITEM No. _____

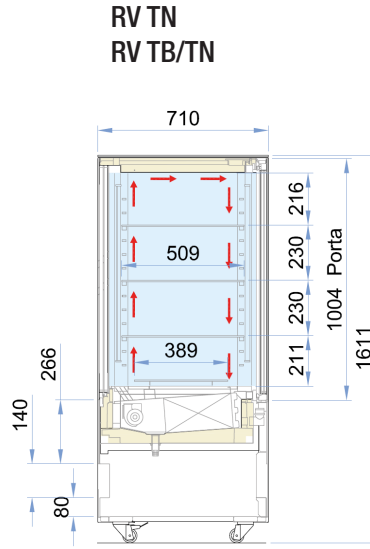
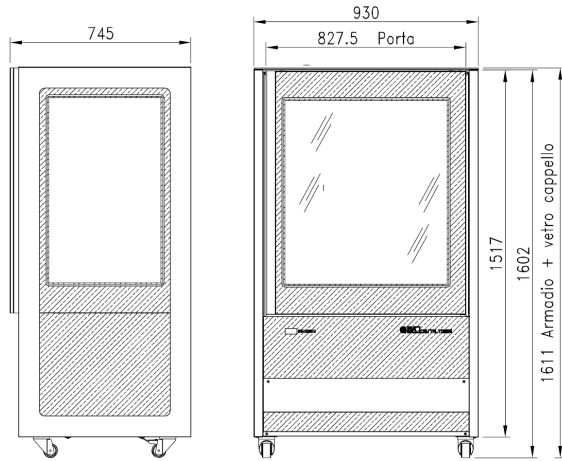

Shelves are adjustable in RV models.

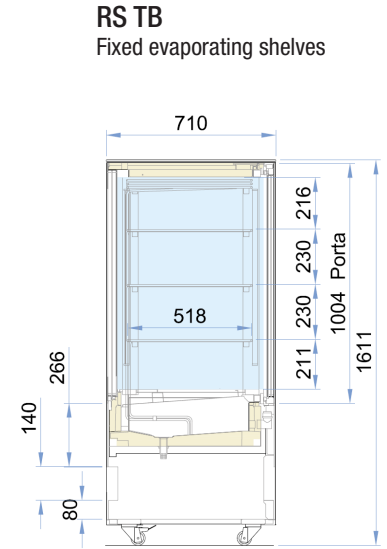

Shelves are fixed in RS model.

CRISTAL TOWER 93LH		Model type	Display area m ²	Temp class	Recomm. temp °C	Energy class	Energy Efficiency Index	Annual Energy kWh/A
Height	Length							
H160 GELATO	93	IVF4	1.74	L1	-20 °C	C (R290)	34.24	5,639
H160 PASTRY	93	IVC4	1.74	M1	+2 °C	B (R290)	15.36	1,767

Configuration: air cooled plug-in unit (R290) double glass doors with automatic opening, LED lighting

CRISTAL TOWER 93LH*	RV TN	RV TB/TN	RS TB
	CHILLED ONLY	CHILLED or FROZEN	FROZEN ONLY
External dimensions (LxDxH)	930 x 745 x 1611 mm		
Shelf dimensions	780 x 465 mm	780 x 465 mm	780 x 498 mm
Capacity (gross/net)	322 / 473 Lt		
Net weight	215 kg		
Refrigeration	Ventilated		Static
Refrigerant	R290		
Climate class	4		
Operating conditions	30 °C / 55 %RH		
Product storage temperature	+1 / +10 °C	-18 / +10 °C	-15 / -18 °C
Compressor (no. - type)	1 - Hermetic		
Defrost process	Off cycle	Hot gas	Manual
Power supply voltage	230v / 50hz / 1ph		
Electrical input (nominal)	500 w / 3.4 A	1050 w / 5.5 A	1170 w / 5.8 A
Electrical input (defrost)	50 w / 0.4 A	1450 w / 6.7 A	N/A

Taylor UK (a division of HTG Trading Ltd)
 106 Claydon Business Park, Gt. Blakenham,
 Ipswich, Suffolk, IP6 0NL, United Kingdom
0800 838 896 - sales@taylor-company.co.uk
www.taylor-company.co.uk

Due to continual research and development, these specifications are subject to change without notification.

CRISTAL TOWER 93LH - Low height pastry showcase - chilled or frozen

*Data for air cooled units. Water cooled and remote installations are available on request.