

# DIVA PASTRY

## Professional ventilated pastry display

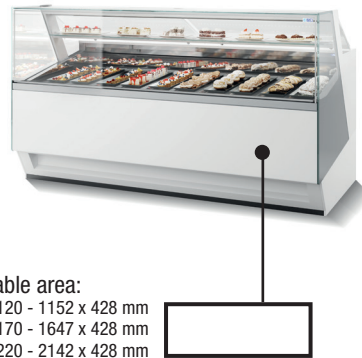

Model PAS RV 220 H125

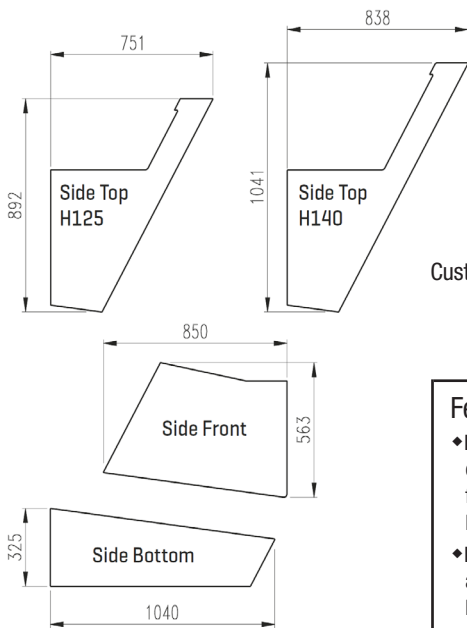

### Customisable area:

- Model 120 - 1152 x 428 mm
- Model 170 - 1647 x 428 mm
- Model 220 - 2142 x 428 mm

ITEM No. \_\_\_\_\_

### Model options:

- DIVA PAS RV 120
- DIVA PAS RV 170
- DIVA PAS RV 220

ALL models listed above are available either H125 or H140 high

### Standard equipment:

- Cool white LED lighting 5700 K°
- Work top - Glacier White Corian™
- Front panel - Glacier White Corian™
- Lower front grill - White (RAL9003)
- Side panels - Glacier White Corian™
- Un-refrigerated glass shelf - 1 in H125, 2 in H140
- Self rolling night curtain
- Swivel castors with brake & adjustable feet

### Optional extras:

- Remote refrigeration installation (call for details)
- Custom RAL panel colours (call for details)
- Front & side panel colours - Clay Corian™  
Pearl Gray Corian™  
Bisque Corian™

### Features:

- ◆ Diva is the new exponent of the elegance by ISA; a perfect balance between design, aesthetics and functionality that enhances the food appeal of the product and gives a touch of charm to the environment, thanks to the volumes, that fit together in a harmonious way, the wide transparent surfaces of the glass frame (without front pillars and with lateral pillars that have reduced thickness) and thanks to the sober and refined nuances of the front and side panels.
- ◆ Diva is equipped with on-board or remote latest generation condenser with double ventilation refrigeration system and inversion defrost cycle. The glass frame with a single glass and laminated sides allow to keep a good balance between performance and aesthetics.
- ◆ The temperature control is adjusted by a control unit and by an anti-fog control system.



**ENERGY SAVING**  
LED lights + EC fan motor



**REFRIGERATION**  
Ventilated



**DEFROST**  
Off cycle



**REFRIGERANT**  
R290



**INSTALLATION**  
Plug-In / Remote (optional)



**TEMPERATURE**  
+1 / +10 °C



**CLIMATE CLASS**  
3



**ENERGY RATING**  
G



Sistema di Qualità  
**ISO 9001**  
Cert. CISQ/CSQ 9130.TAIF



Sistema di Qualità  
**ISO 14001**  
Cert. CIS ECO ISO 9191.ISA3



**Taylor UK** (a division of HTG Trading Ltd)  
106 Claydon Business Park, Gt. Blakenham,  
Ipswich, Suffolk, IP6 0NL, United Kingdom  
**0800 838 896 - sales@taylor-company.co.uk**  
**www.taylor-company.co.uk**

Due to continual research and development, these specifications are subject to change without notification.

March 2021

# DIVA PASTRY



## Professional ventilated pastry display

Section view: (all dimensions in mm)

ITEM No. \_\_\_\_\_

### H125

1M: single shelf

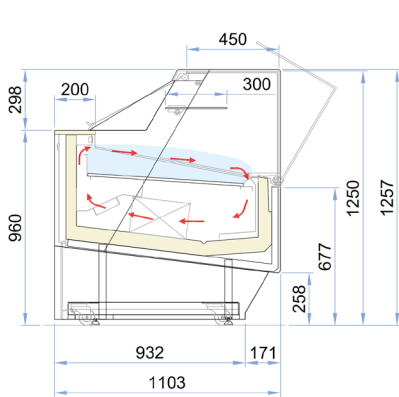

### H140

2M: two shelves

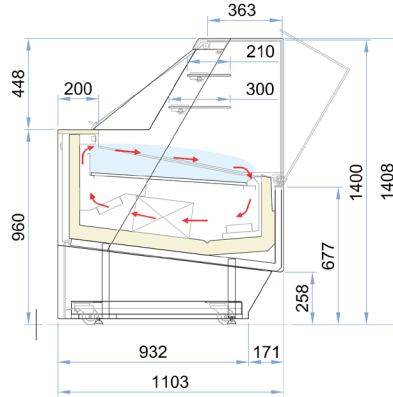

DIVA - PAS		Model type	Display area m <sup>2</sup>	Temp class	Reccom. temp °C	Energy class	Energy Efficiency Index	Annual Energy kWh/A
Height	Length							
H125	120	IHC7	0.71	M1	+2 °C	G (R290)	84.97	5,533
	170	IHC7	1.07	M1	+2 °C	G (R290)	93.73	6,658
	220	IHC7	1.43	M1	+2 °C	G (R290)	98.66	7,992
H140	120	IHC7	0.71	M1	+2 °C	G (R290)	89.64	5,861
	170	IHC7	1.07	M1	+2 °C	G (R290)	97.08	7,118
	220	IHC7	1.43	M1	+2 °C	G (R290)	98.92	8,583

Configuration: air cooled plug-in unit (R290) plexiglass sliding door closure, LED lighting, illuminated shelves

DIVA PAS*	RV 120	RV 170	RV 220
External dimensions (LxDxH) H125	1176 x 1103 x 1257 mm	1671 x 1103 x 1257 mm	2166 x 1103 x 1257 mm
External dimensions (LxDxH) H140	1176 x 1103 x 1408 mm	1671 x 1103 x 1408 mm	2166 x 1103 x 1408 mm
Net weight H125	295 kg	375 kg	470 kg
Net weight H140	318 kg	400 kg	492 kg
Refrigeration	Ventilated		
Refrigerant	R290		
Climate class	3		
Operating conditions	25 °C / 60 %RH		
Product storage temperature	+1 / +10 °C		
Compressor (no. - type)	1 - Hermetic		
Defrost process	Off cycle		
Power supply voltage	230v / 50hz / 1ph		
Electrical input (nominal)	1350 w / 6.5 A	1620 w / 7.8 A	2120 w / 10.2 A
Electrical input (defrost)	520 w / 2.8 A	490 w / 2.7 A	590 w / 3.2 A

Taylor UK (a division of HTG Trading Ltd)  
 106 Claydon Business Park, Gt. Blakenham,  
 Ipswich, Suffolk, IP6 ONL, United Kingdom  
 0800 838 896 - sales@taylor-company.co.uk  
 www.taylor-company.co.uk

Due to continual research and development, these specifications are subject to change without notification.

DIVA PASTRY – Professional ventilated pastry display

\*Data for air cooled units. Water cooled and remote installations are available on request.