

KALEIDO PASTRY

Professional ventilated pastry display



ITEM No. _____

Model options:

- KALEIDO PAS RV 120
- KALEIDO PAS RV 170
- KALEIDO PAS RV 220

ALL models listed above are available either H117 or H135 high

Standard equipment:

- Cool white LED lighting 5700 K°
- Work top - Glacier White Corian™
- Front panel - Black back-painted glass
- Lower front grill - Grey (RAL9007)
- Side panels - Grey (RAL9007) lacquered
- Refrigerated glass shelf - 1 in H117 , 2 in H135
- Plexiglass sliding doors
- Swivel castors with brake & adjustable feet

Optional extras:

- Self rolling night curtain
- RGB LED lighting behind front panel
- Remote refrigeration installation (call for details)
- Front panel finishes - Vetro Rosso
Pelli Di Struzzo
Alicrite



Model PAS RV 170 H135
with optional Pelle Di Struzzo front finish

Features:

- ◆ Pastry display case with ventilated refrigeration system with "FULL MODE" to also allow cooling of the shelves. One piece body insulated with ecological polyurethane (HCFC & HFC free) CO2 foam, 60 mm thick.
- ◆ Display deck tilted by 4°. Service shelf in corian and the operator's side rear panel in epoxy powder-coated carbon steel.
- ◆ Shelves adjustable in depth. Two refrigerated shelves in the H135 model and one shelf in the H117 model.
- ◆ Double glazed heated front glass opens via top mounted hydraulic pistons. Aesthetic side panels made of laminate and lacquered on the lower part, double glazed heated glass on the upper section.
- ◆ Interior lighting with LED strip on top and on each shelf.
- ◆ Structure base in, epoxy powder-coated carbon steel with adjustable feet and rotating castors.
- ◆ Control panel with electronic control unit, located on lower part of operator's side and digital thermometer placed inside well.



ENERGY SAVING
LED lights + EC fan motor



REFRIGERATION
Ventilated



DEFROST
Off cycle



REFRIGERANT
R290



INSTALLATION
Plug-In / Remote (optional)



TEMPERATURE
+1/ +10 °C



CLIMATE CLASS
3



ENERGY RATING
F



Sistema di Qualità
ISO 9001
Cert. CISQ/CSQ 9130.TAIF



Sistema di Qualità
ISO 14001
Cert. CIS ECO ISO 9191.ISA3

aria ISO 14064



Taylor UK
Catering Equipment Specialists

Taylor UK (a division of HTG Trading Ltd)
106 Claydon Business Park, Gt. Blakenham,
Ipswich, Suffolk, IP6 0NL, United Kingdom
0800 838 896 - sales@taylor-company.co.uk
www.taylor-company.co.uk

Due to continual research and development, these specifications are subject to change without notification.

March 2021

KALEIDO PASTRY



Professional ventilated pastry display

Section view: (all dimensions in mm)

ITEM No. _____

H117

1M: single shelf

H135

2M: two shelves

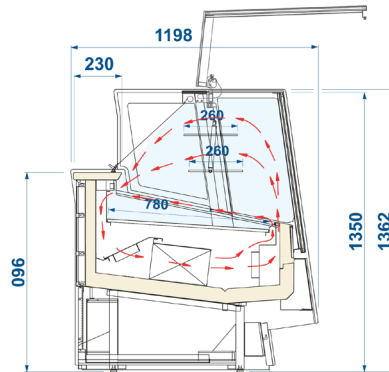
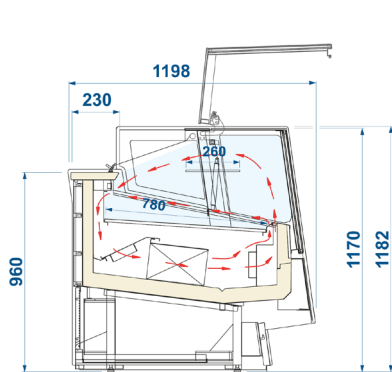

KALEIDO - PAS		Model type	Display area m ²	Temp class	Reccom. temp °C	Energy class	Energy Efficiency Index	Annual Energy kWh/A
Height	Length							
H117	120	IVC4	1.29	H	+6 °C	F (R290)	76.29	5,240
	170	IVC4	1.79	H	+6 °C	F (R290)	75.39	6,302
	220	IVC4	2.29	H	+6 °C	F (R290)	76.78	7,562
H135	120	IVC4	1.71	H	+6 °C	F (R290)	68.48	5,568
	170	IVC4	2.34	H	+6 °C	F (R290)	67.51	6,762
	220	IVC4	2.97	H	+6 °C	F (R290)	68.51	8,154

Configuration: air cooled plug-in unit (R290) plexiglass sliding door closure, LED lighting, illuminated shelves

KALEIDO PAS*	RV 120	RV 170	RV 220
External dimensions (LxDxH) H117	1182 x 1198 x 1182 mm	1677 x 1198 x 1182 mm	2172 x 1198 x 1182 mm
External dimensions (LxDxH) H135	1182 x 1198 x 1362 mm	1677 x 1198 x 1362 mm	2172 x 1198 x 1362 mm
Net weight H117	320 kg	409 kg	510 kg
Net weight H135	346 kg	434 kg	535 kg
Refrigeration	Ventilated		
Refrigerant	R452A		
Climate class	3		
Operating conditions	25 °C / 60 %RH		
Product storage temperature	+1 / +10 °C		
Compressor (no. - type)	1 - Hermetic		
Defrost process	Off cycle		
Power supply voltage	230v / 50hz / 1ph		
Electrical input (nominal)	1360 w / 7.4 A	1485 w / 8.1 A	1610 w / 8.7 A
Electrical input (defrost)	420 w / 2.3 A	485 w / 2.6 A	450 w / 2.4 A

Taylor UK (a division of HTG Trading Ltd)
 106 Claydon Business Park, Gt. Blakenham,
 Ipswich, Suffolk, IP6 ONL, United Kingdom
0800 838 896 - sales@taylor-company.co.uk
www.taylor-company.co.uk

Due to continual research and development, these specifications are subject to change without notification.

*Data for air cooled units. Water cooled and remote installations are available on request.

KALEIDO PASTRY – Professional ventilated pastry display