

STRATOS PASTRY

Professional ventilated pastry display



Model PAS RV 170

ITEM No. _____

Model options:

- STRATOS PAS RV 120
- STRATOS PAS RV 170
- STRATOS PAS RV 220

Standard equipment:

- Cool white LED lighting 5700 K°
- Work top - Glacier White Corian™
- Front panel - White Pearl (RAL1013)
- Internal front panel - Black (RAL9005)
- Side panels - White Pearl (RAL1013)
- Refrigerated shelf above display (1)
- Plexiglass sliding doors
- Heated upper glass anti-condensation system
- Swivel castors with brake & adjustable feet

Optional extras:

- Self rolling night curtain
- Remote refrigeration installation (call for details)
- Custom RAL panel colours (call for details)
- White Pearl internal front panel (RAL1013)
- Black side panels (RAL9005)



Customisable area:

- Model 120 - 1150 x 240 mm
- Model 170 - 1645 x 240 mm
- Model 220 - 2140 x 240 mm

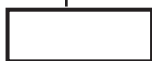

Features:

- ◆ Stratos Pastry is the new ISA high-end display cabinet that combines maximum technical performance with aesthetics that fully reflect the elegance and unmistakable style of Italian design.
- ◆ Stratos has front glass and side glass windows with heated chamber and a heatable laminated upper glass with servo assisted manual opening.



ENERGY SAVING
LED lights + EC fan motor



REFRIGERATION
Ventilated



DEFROST
Off cycle



REFRIGERANT
R290



INSTALLATION
Plug-In / Remote (optional)



TEMPERATURE
+1 / +10 °C



CLIMATE CLASS
3



ENERGY RATING
F



Sistema di Qualità
ISO 9001
Cert. CISQ/CSQ 9130.TAIF



Sistema di Qualità
ISO 14001
Cert. CIS ECO ISO 9191.ISA3



Taylor UK (a division of HTG Trading Ltd)
106 Claydon Business Park, Gt. Blakenham,
Ipswich, Suffolk, IP6 0NL, United Kingdom
0800 838 896 - sales@taylor-company.co.uk
www.taylor-company.co.uk

Due to continual research and development, these specifications are subject to change without notification.

March 2021

STRATOS PASTRY – Professional ventilated pastry display

STRATOS PASTRY



Professional ventilated pastry display

Section view: (all dimensions in mm)

ITEM No. _____

H125

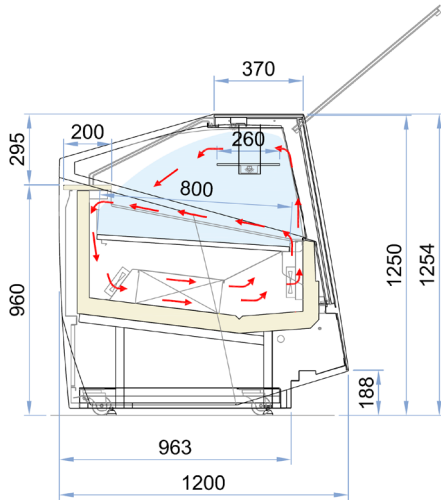

STRATOS - PAS		Model type	Display area m ²	Temp class	Reccom. temp °C	Energy class	Energy Efficiency Index	Annual Energy kWh/A
Height	Length							
H125	120	IVC4	1.54	H	+6 °C	F (R290)	68.52	5,209
	170	IVC4	2.10	H	+6 °C	F (R290)	68.02	6,325
	220	IVC4	2.67	H	+6 °C	F (R290)	69.37	7,627

Configuration: air cooled plug-in unit (R290) plexiglass sliding door closure, LED lighting

STRATOS PAS*	RV 120	RV 170	RV 220
External dimensions (LxDxH)	1190 x 1200 x 1254 mm	1685 x 1200 x 1254 mm	2180 x 1200 x 1254 mm
Capacity (gross/net)	720 / 240 ltr	1059 / 317 ltr	1398 / 418 ltr
Net weight	400 kg	460 kg	510 kg
Refrigeration	Ventilated		
Refrigerant	R290		
Climate class	3		
Operating conditions	25 °C / 60 %RH		
Product storage temperature	+1 / +10 °C		
Compressor (no. - type)	1 - Hermetic		
Defrost process	Off cycle		
Power supply voltage	230v / 50hz / 1ph		
Electrical input (nominal)	1240 w / 6.0 A	1720 w / 3.0 A	2700 w / 4.2 A
Electrical input (defrost)	2300 w / 11.0 A	2950 w / 4.9 A	6300 w / 8.5 A

Sistema di Qualità
ISO 9001
Cert. CISQ/CSQ 9130.TAIF

Sistema di Qualità
ISO 14001
Cert. CIS ECO ISO 9191.ISA3

ISO 14064

Catering Equipment Specialists

Taylor UK (a division of HTG Trading Ltd)
 106 Claydon Business Park, Gt. Blakenham,
 Ipswich, Suffolk, IP6 0NL, United Kingdom
0800 838 896 - sales@taylor-company.co.uk
www.taylor-company.co.uk

Due to continual research and development, these specifications are subject to change without notification.

STRATOS PASTRY - Professional ventilated pastry display

*Data for air cooled units. Water cooled and remote installations are available on request.