

SUPERCAPRI PASTRY



Professional ventilated pastry display

ITEM No. _____

Model options:

- SUPERCAPRI PAS RV 120
- SUPERCAPRI PAS RV 170
- SUPERCAPRI PAS RV 220

ALL models listed above are available either H117 or H135 high

Standard equipment:

- Cool white LED lighting 5700 K°
- Work top - Glacier White Corian™
- Front panel - Grey (RAL7022) lacquered
- Lower front grill - Grey (RAL7022) lacquered
- Side panels - Grey (RAL7022) lacquered
- Refrigerated glass shelf - 1 in H117, 2 in H135
- Plexiglass sliding doors
- Swivel castors with brake & adjustable feet

Optional extras:

- Self rolling night curtain
- Remote refrigeration installation (call for details)
- Custom RAL panel colours (call for details)
- Front & side panel colours - White Lacquer (RAL9003)
Black Lacquer (RAL9005)



Model PAS RV 220 H135



Model PAS RV 220 H135

Customisable area:

- Model 120 - 1152 x 440 mm
- Model 170 - 1647 x 440 mm
- Model 220 - 2142 x 440 mm



Side dimensions:

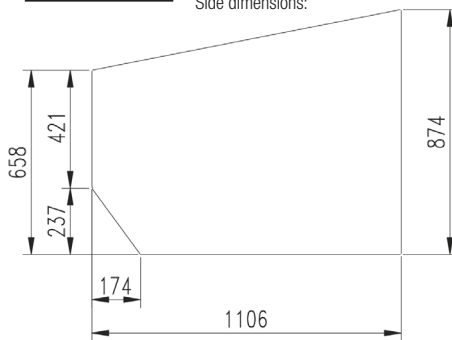

Features:

- ◆ Supercapri is the synthesis of an essential design and high-level technical features. It is equipped with glass side windows with heated chamber and heatable laminated front glass that can be opened.
- ◆ Refrigerated shelves, one in H117 and two in H135



ENERGY SAVING
LED lights + EC fan motor



REFRIGERATION
Ventilated



DEFROST
Off cycle



REFRIGERANT
R290



INSTALLATION
Plug-In / Remote (optional)



TEMPERATURE
+1 / +10 °C



CLIMATE CLASS
3



ENERGY RATING
E & F



Sistema di Qualità
ISO 9001
Cert. CISQ/CSQ 9130.TAIF



Sistema di Qualità
ISO 14001
Cert. CIS ECO ISO 9191.ISA3



Taylor UK (a division of HTG Trading Ltd)
106 Claydon Business Park, Gt. Blakenham,
Ipswich, Suffolk, IP6 0NL, United Kingdom
0800 838 896 - sales@taylor-company.co.uk
www.taylor-company.co.uk

Due to continual research and development, these specifications are subject to change without notification.

March 2021

SUPERCAPRI PASTRY



Professional ventilated pastry display

Section view: (all dimensions in mm)

ITEM No. _____

H117

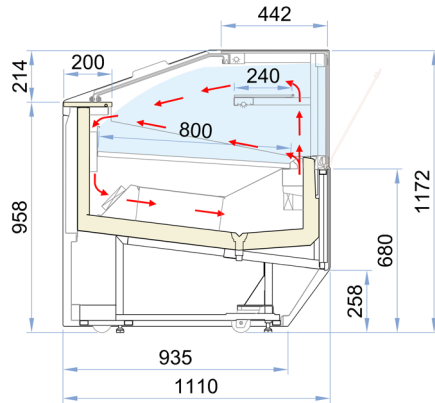

H135

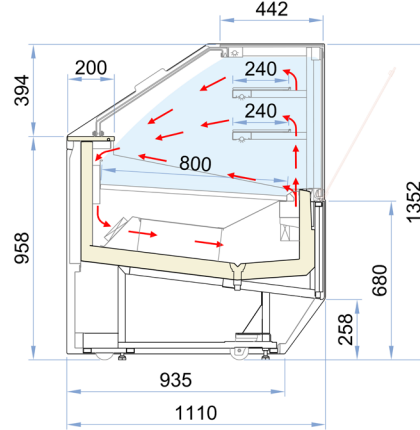

SUPERCAPRI - PAS		Model type	Display area m ²	Temp class	Reccom. temp °C	Energy class	Energy Efficiency Index	Annual Energy kWh/A
Height	Length							
H117	120	IVC4	1.51	H	+6 °C	F (R290)	73.66	5,533
	170	IVC4	2.05	H	+6 °C	F (R290)	72.82	6,658
	220	IVC4	2.60	H	+6 °C	F (R290)	74.18	7,992
H135	120	IVC4	2.05	H	+6 °C	E (R290)	64.18	5,861
	170	IVC4	2.75	H	+6 °C	E (R290)	63.33	7,118
	220	IVC4	3.45	H	+6 °C	E (R290)	64.32	8,583

Configuration: air cooled plug-in unit (R290) plexiglass sliding door closure, LED lighting, illuminated shelves

SUPERCAPRI PAS*	RV 120	RV 170	RV 220
External dimensions (LxDxH) H117	1187 x 1110 x 1175 mm	1682 x 1110 x 1175 mm	2177 x 1110 x 1175 mm
External dimensions (LxDxH) H135	1187 x 1110 x 1352 mm	1682 x 1110 x 1352 mm	2177 x 1110 x 1352 mm
Net weight H117	300 kg	375 kg	470 kg
Net weight H135	325 kg	410 kg	510 kg
Refrigeration	Ventilated		
Refrigerant	R290		
Climate class	3		
Operating conditions	25 °C / 60 %RH		
Product storage temperature	+1 / +10 °C		
Compressor (no. - type)	1 - Hermetic		
Defrost process	Off cycle		
Power supply voltage	230v / 50hz / 1ph		
Electrical input (nominal)	1360 w / 7.4 A	1485 w / 8.1 A	1610 w / 8.7 A
Electrical input (defrost)	420 w / 2.3 A	485 w / 2.6 A	450 w / 2.4 A

Taylor UK (a division of HTG Trading Ltd)
 106 Claydon Business Park, Gt. Blakenham,
 Ipswich, Suffolk, IP6 ONL, United Kingdom
0800 838 896 - sales@taylor-company.co.uk
www.taylor-company.co.uk

Due to continual research and development, these specifications are subject to change without notification.

*Data for air cooled units. Water cooled and remote installations are available on request.

SUPERCAPRI PASTRY - Professional ventilated pastry display