



Item No. \_\_\_\_\_

# C854 McD

## Electric Clamshell Grill



C854 MCD

### Features

One-touch menu selection automatically chooses the proper TIME, TEMPERATURE, and GAP settings. Modular design allows for future volume growth.

### True Parallel Auto Leveling

Automated procedure sets the lower plate parallel to the upper platen. Increases food quality through consistently accurate gap settings.

### Programmable Controls

Automatically determines product placed on the grill and sets cook time and multi-gap parameters. Easier to operate and eliminates need to change product settings, which improves flexibility. Microprocessor controls are programmable for simplified crew operation. Also offers flexibility for future menu items and product specification changes at the restaurant level.

### Upper Platens

Upper platen may be lowered manually for quick closing, or will close automatically to the preset gap setting with the touch of one button. Slim platen design makes cleaning easier for crew. As a safety feature, platen will automatically open at loss of power, or if an obstruction is detected.

### Precise Automatic Gapping

With the unique three-point reference system, the lower plate automatically achieves accurate and consistent gaps every time. Precise, repeatable gapping results in consistent, better quality finished product.

### Cooking Zones

Two controlled cooking positions. Two independent heating elements in the lower cooking surface, and two in the upper platen, assures even temperatures and quick recovery. A larger cooking gap allows products up to 2.0" thick to be cooked in two-sided mode, enabling greater menu flexibility.

### Wrap-Around Release Material

Protects the entire upper platen cooking surface and makes cleaning easy. Improved install and removal process away from hot surfaces. Simple-to-install upper platen release material incorporates a tail that directs cooking vapors to the cooking zone instead of to the back of the grill. This results in a grill that is easier to clean and cooking vapors that are easily collected by the cooking hood for evacuation.

### C850/854 Only

Outrigger kit - X87115 (C850) w/o casters and Outrigger kit X87155 (C854) w/o casters are to be applied during store installation.



Rockton, Illinois 61072  
**Toll Free: 1-877-HELP-MCD**  
Phone 815-624-8333 Fax 815-624-8000  
[www.taylor-company.com](http://www.taylor-company.com)  
e-mail: [helpmcd@taylor-company.com](mailto:helpmcd@taylor-company.com)

ISO 9001:2015  
Registered Firm



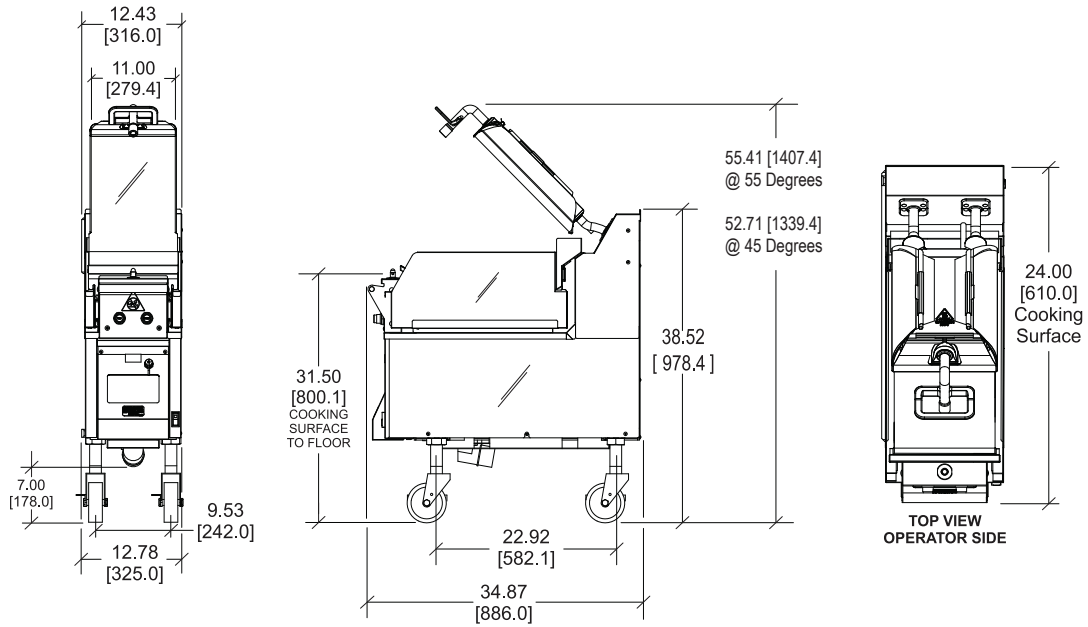

FIGURES IN BRACKETS INDICATE MILLIMETERS / DECIMAL AND FRACTIONAL DIMENSIONS EQUAL TO ( PLUS OR MINUS 1/16 INCH [1.5mm] ).  
MACHINE HEIGHT CAN VARY ( PLUS OR MINUS 3 INCHES [76.2MM] ) WITH CASTER HEIGHT ADJUSTMENT

Weights	lbs.	kgs.
Net	344	156
Crated	405	183.7
Volume	cu. ft.	cu. m.
	38.7	1.1
Dimensions	in.	mm.
Width	12-7/16	316
Depth	34-7/8	886
Height	52-3/4 to 55-7/16	1339 to 1407
Cooking Surface Height	29 to 34	737 to 864
Floor Clearance	6-13/16 to 11-13/16	173 to 300

*Casters may be adjusted.*

Electrical	Amps Per Cord	Total KW	Interlock/Control Voltage	Interlock Fuse Size
220/380/3	12	6.4	220/60/1	7 amps
400/50/3	12	6.4	230/50/1	7 amps

## Specifications

### Electrical

Standard is 400/50/3 phase.  
One dedicated three-phase electrical connection is required. See the Electrical chart for the proper electrical requirements. Manufactured to be permanently connected. Consult your KES or local Taylor distributor for cord & receptacle specifications as local codes allow.

**NOTE: Taylor Model C854 Clamshell Grills may be installed only in McDonalds Corporation Restaurants.**

This unit may be manufactured in other electrical characteristics and may have additional regulatory agency approvals. Consult the local Taylor Distributor for other electrical characteristics and agency approvals based on specific electrical and country requirements.

**(For exact electrical information and approval marks, always refer to the data label of the unit.)**

**Continuing research results in steady improvements; therefore, these specifications are subject to change without notice.**

### Bidding Specs

Electrical: Volt \_\_\_\_\_ Hz \_\_\_\_\_ ph \_\_\_\_\_  
Neutral: Yes No **Cooling:** Air Water NA

Options: \_\_\_\_\_

### Authorized Taylor Distributor



**TAYLOR UK** (A division of HTG Trading Ltd)  
106 Claydon Business Park, Gt. Blakenham,  
Ipswich, Suffolk, United Kingdom  
Tel: (+44) 01473 350046  
Email: [sales@taylor-company.co.uk](mailto:sales@taylor-company.co.uk)  
Web: [www.taylor-company.co.uk](http://www.taylor-company.co.uk)



750 N. Blackhawk Blvd.  
Rockton, Illinois 61072  
[www.taylor-company.com](http://www.taylor-company.com)