

CASADIO UNDICI



Traditional espresso machines

ITEM No. _____

Model options:

- UNDICI DT1
- UNDICI DT2
- UNDICI DT2 COMPACT

Standard equipment:

- 1x Single portafilter
- 1x Double portafilter
- 1x Rubber cleaning blank
- PSSR safety certificate
- Starter pack cleaning chemicals

Optional extras:

- Water filter kit
- Additional single portafilter
- Additional double portafilter
- Standard tamper
- Standard knock out draw



CASADIO UNDICI DT2



CASADIO UNDICI DT1



CASADIO UNDICI DT2 COMPACT

Features:

Undici is a compact, elegant, versatile machine that's easy to use, adjust and maintain. UNDICI is made of steel and aluminium. It has a fixed nozzle thermosiphon system that's adaptable and high performing, guaranteeing excellent results in the cup.

The mechanical button pad is in metal and lies flush with the machine. It's user-friendly and precise, thanks to the LED lights.

- Fixed-nozzle thermosiphon system that's adaptable and high performing, guaranteeing excellent results in the cup.
- UNDICI is made of steel and aluminium to guarantee the best in robustness and reliability.
- UNDICI can be personalised thanks to the new, mechanical button pad with LEDs that make it user-friendly and precise.
- Stainless steel steam wand.
- Each group is equipped with four dosing selections and one continuous delivery.
- Stainless steel hot water dispenser (metered - selections).
- Graphic display with easy and ergonomic push-button programming.
- Electric cup warmer.

CASADIO UNDICI - Traditional espresso machines



Taylor UK (a division of HTG Trading Ltd)

106 Claydon Business Park, Gt. Blakenham, Ipswich, Suffolk, IP6 0NL, United Kingdom

0800 838 896 - sales@taylor-company.co.uk

www.taylor-company.co.uk

Due to continual research and development, these specifications are subject to change without notification.

June 2021

CASADIO UNDICI





ITEM No. _____

Traditional espresso machines

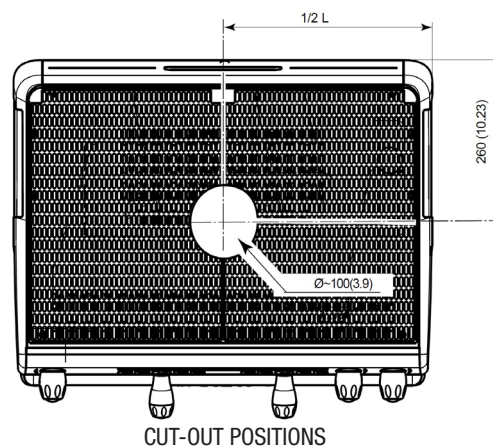
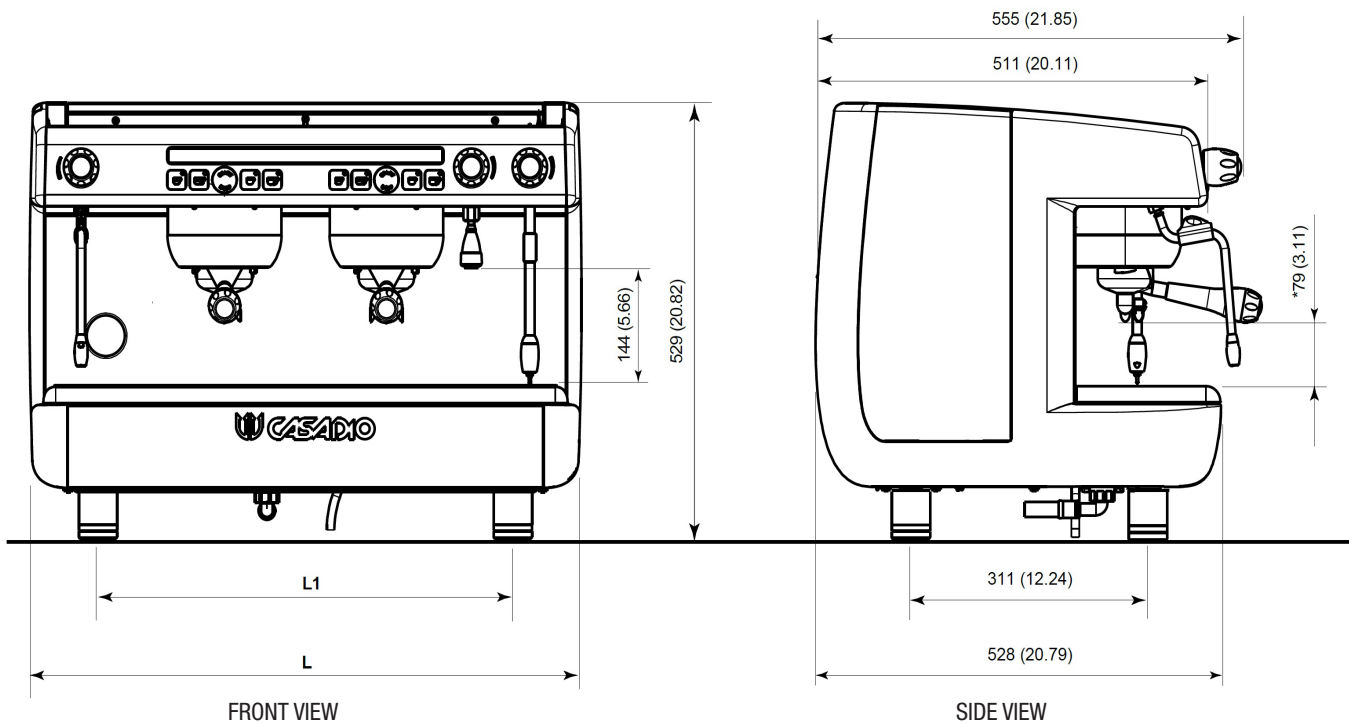
Section view - dimensions in mm (inches):



CASADIO UNDICI	DT1	DT2	DT2 COMPACT
	Single Group	Twin Group	Twin Group
External dimensions (WxDxH)	432 x 528 x 570 mm	712 x 528 x 570 mm	550 x 528 x 529 mm
Net weight	50 Kg	70 Kg	65 Kg
Hot water / No.	YES / 1		
Steam wand / No.	YES - 1		YES - 2
Boiler - No. / capacity	1 / 5.0 litre	1 / 10.5 litre	1 / 7.0 litre
Maximum cup height	79 mm		
Water / waste connection*	2 Bar potable water (3/4" BSP shut off) / downpipe with U-bend (1-3/4")		
Voltage	230v / 50Hz / 1Ph		
Installed power	3,000 W	3,300 W	
Circuit breaker/fuse	13 amp	16 amp	
Power socket	13 amp (1P+N+E) 	16 amp (1P+N+E) 	

PLEASE NOTE: All counter cut-outs and utilities must be made and installed by the customer prior to delivery and installation.

*ALL La Cimbali coffee machines require a 2 Bar potable water supply (fitted with a suitable water filtration device) terminating in a 3/4" BSP shut-off valve and 1-3/4" waste downpipe with U-bend. Water and waste utilities must be located directly beneath the final position of the coffee machine.

Failure to have suitable utilities and counter cut-outs in place at point of installation may result in an aborted installation and will be chargeable.



Taylor UK (a division of HTG Trading Ltd)
106 Claydon Business Park, Gt. Blakenham,
Ipswich, Suffolk, IP6 0NL, United Kingdom
0800 838 896 - sales@taylor-company.co.uk
www.taylor-company.co.uk

Due to continual research and development, these specifications are subject to change without notification.

June 2021

CASADIO UNDICI - Traditional espresso machines