



# JOSPER ROBATAGRILL RGJ

## TECHNICAL INFORMATION

Braising area	478 x 166 mm (x3)	18 7/8 x 6 1/2 in (x3)
Fire up time	20 min average	
Broiling temperature	250 °C	482 °F
Charcoal daily consumption	8 to 10 kg	17.6 to 22 lb
Nominal heat output	1 kW	1.34 hp
Net weight	65 kg	143.3 lb

## INSTALLATION

Recommended installation height	630 mm	24 7/8 in
Clearance with non-flammable equipment	100 mm	4 in
Clearance with flammable equipment	300 mm	12 in
Exhaust rate	2500 m³/h	1471 cfm

## COMBUSTION SHIELD MEASURES

## RECESSED INSTALLATION

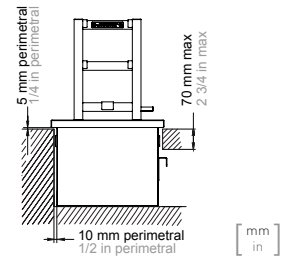
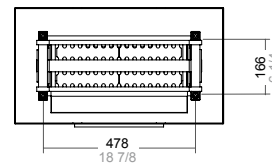

## RGJ-050

The Jospers Robotagrill is the new charcoal grill for cooking in the robotayaki style, an ancient technique of Japanese culture consisting of grilling in front of the diners. The small portions of food are grilled on skewers over hot charcoal. Ideal for cooking all types of meat and fish in a unique way, where the ingredients never lose the original flavor. This method of Asian cuisine is very adaptable for many styles and other gastronomic cultures. The Jospers Robotagrill offers several levels of grilling and includes different types of accessories for working over charcoal kebabs, grills, Teppanyaki... With the Robotagrill you will enjoy live cooking and will see how the chefs prepare their dishes around the grill... A real culinary show.

### ACCESSORIES INCLUDED

Skewer supports · Tongs · Temperature regulation grate · Grease tray



Ed.10.2020 - Jospers reserves the right to make modifications to catalogues, pricelists and promotional material according to the development and improvements applied to its equipment.



# JOSPER ROBATAGRILL RGJ

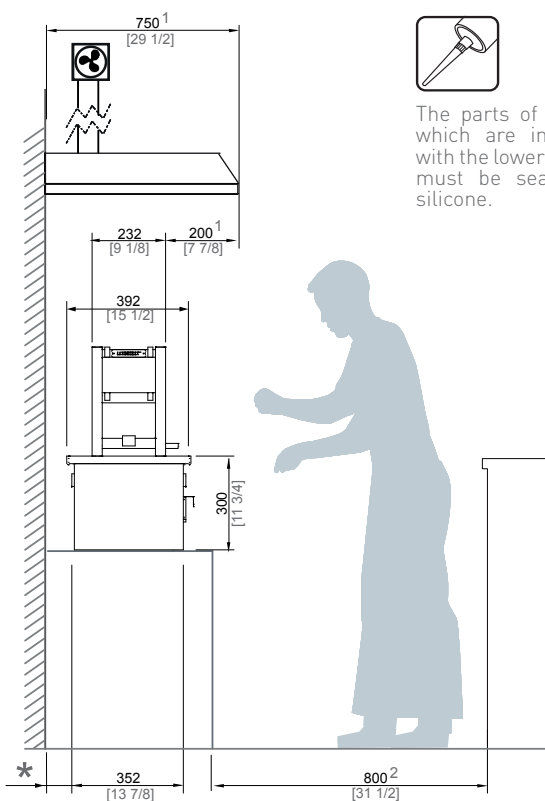
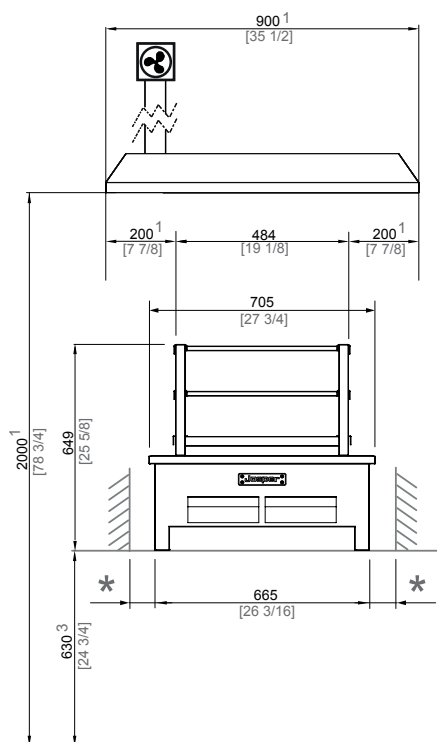
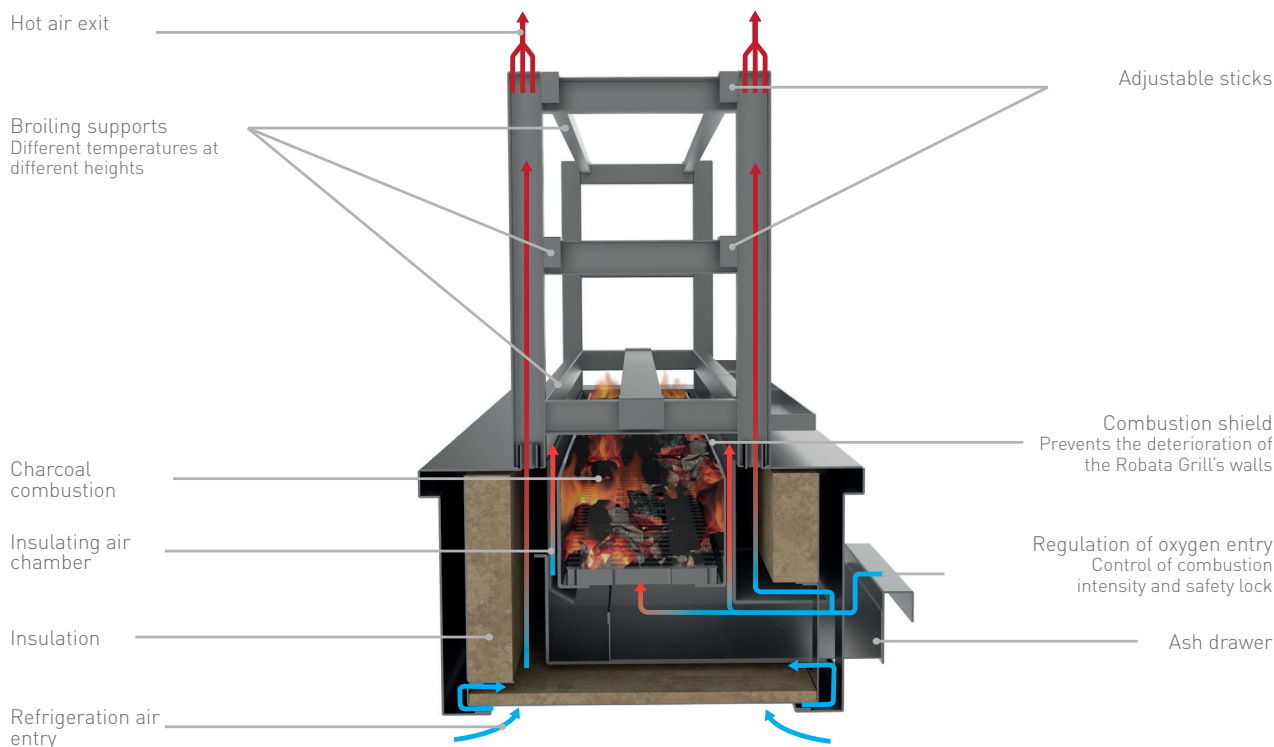

\* MINIMUM DISTANCE TO FLAMMABLE ELEMENTS: 300 mm [12 in] / RECOMMENDED DISTANCE TO ANOTHER ELEMENTS: 100 mm [4 in]

1 RECOMMENDED HOOD'S MINIMUM DIMENSIONS

2 RECOMMENDED CHEF'S WORKING SPACE

3 RECOMMENDED INSTALLATION HEIGHT

[ mm  
in ]



# JOSPER ROBATAGRILL RGJ

## TECHNICAL INFORMATION

Braising area	978 x 166 mm (x3)	38 1/2 x 6 1/2 in (x3)
Fire up time	20 min average	
Broiling temperature	250 °C	482 °F
Charcoal daily consumption	10 to 12 kg	22 to 26.5 lb
Nominal heat output	2 kW	2.68 hp
Net weight	111 kg	244.7 lb

## INSTALLATION

Recommended installation height	630 mm	24 7/8 in
Clearance with non-flammable equipment	100 mm	4 in
Clearance with flammable equipment	300 mm	12 in
Exhaust rate	3200 m <sup>3</sup> /h	1883 cfm

## COMBUSTION SHIELD MEASURES

## RECESSED INSTALLATION

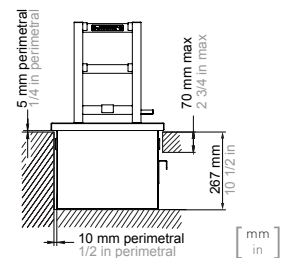
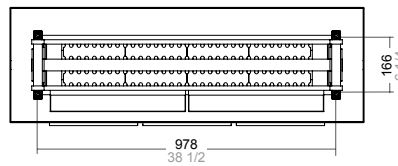

## RGJ-100

The Josper Robatagrill is the new charcoal grill for cooking in the robatayaki style, an ancient technique of Japanese culture consisting of grilling in front of the diners. The small portions of food are grilled on skewers over hot charcoal. Ideal for cooking all types of meat and fish in a unique way, where the ingredients never lose the original flavor. This method of Asian cuisine is very adaptable for many styles and other gastronomic cultures. The Josper Robatagrill offers several levels of grilling and includes different types of accessories for working over charcoal kebabs, grills, Teppanyaki... With the Robatagrill you will enjoy live cooking and will see how the chefs prepare their dishes around the grill... A real culinary show.

### ACCESSORIES INCLUDED

Skewer supports · Tongs · Temperature regulation grate · Grease tray



Ed.01.2021 - Josper reserves the right to make modifications to catalogues, pricelists and promotional material according to the development and improvements applied to its equipment.

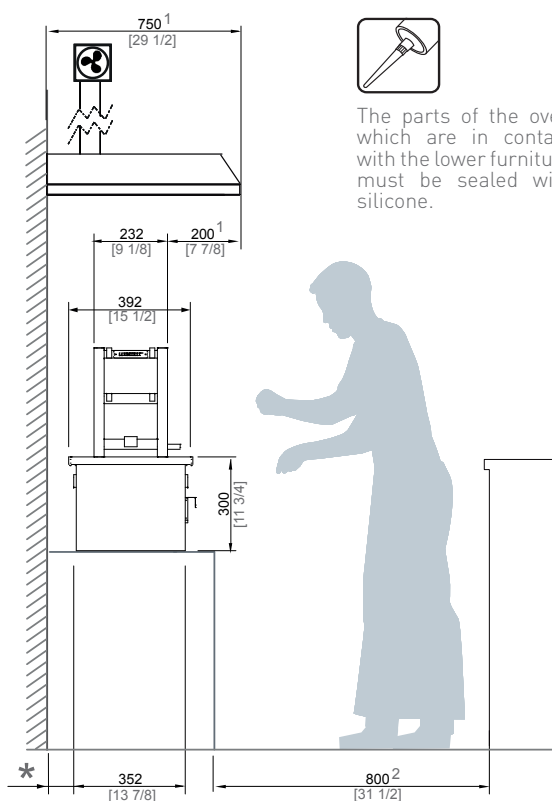
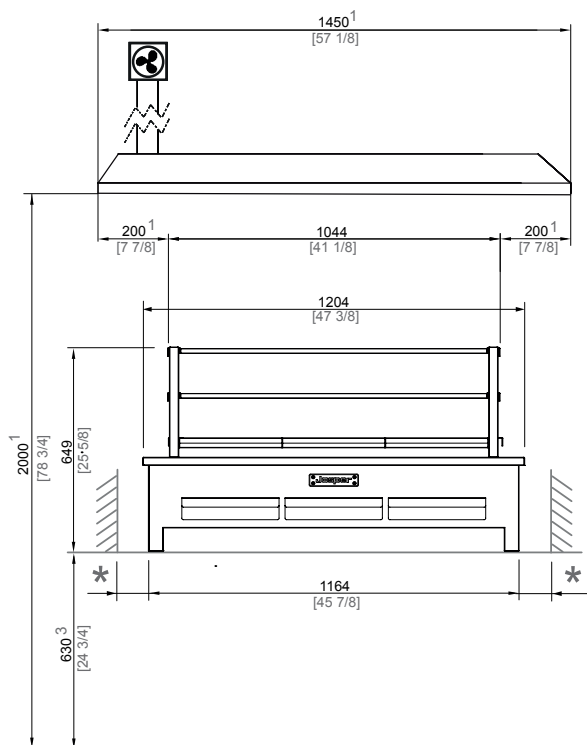
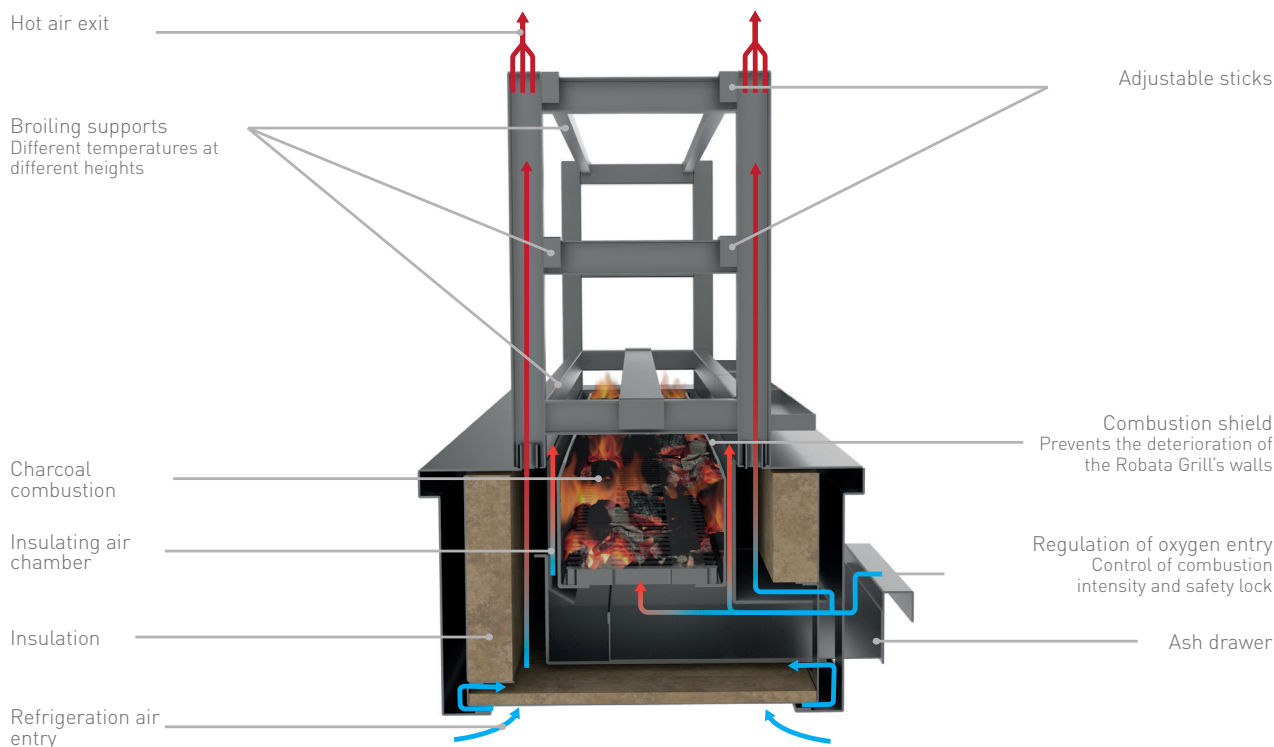

\* MINIMUM DISTANCE TO FLAMMABLE ELEMENTS: 300 mm [12 in] / RECOMMENDED DISTANCE TO ANOTHER ELEMENTS: 100 mm [4 in]

1 RECOMMENDED HOOD'S MINIMUM DIMENSIONS

2 RECOMMENDED CHEF'S WORKING SPACE

3 RECOMMENDED INSTALLATION HEIGHT

[ mm  
in ]



# JOSPER ROBATAGRILL RGJ

## TECHNICAL INFORMATION

Braising area	1378 x 166 mm (x3)	54 1/4 x 6 1/2 in (x3)
Fire up time	20 min average	
Broiling temperature	250 °C	482 °F
Charcoal daily consumption	12 to 14 kg	26.5 to 31 lb
Nominal heat output	3 kW	4.02 hp
Net weight	157 kg	346.1 lb

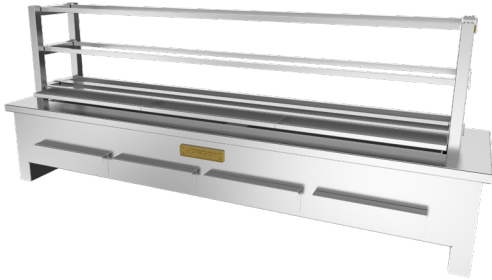

## INSTALLATION

Recommended installation height	630 mm	24 7/8 in
Clearance with non-flammable equipment	100 mm	4 in
Clearance with flammable equipment	300 mm	12 in
Exhaust rate	3800 m <sup>3</sup> /h	2237 cfm

## RGJ-140

The Josper Robotagrill is the new charcoal grill for cooking in the robotayaki style, an ancient technique of Japanese culture consisting of grilling in front of the diners. The small portions of food are grilled on skewers over hot charcoal. Ideal for cooking all types of meat and fish in a unique way, where the ingredients never lose the original flavor. This method of Asian cuisine is very adaptable for many styles and other gastronomic cultures. The Josper Robotagrill offers several levels of grilling and includes different types of accessories for working over charcoal kebabs, grills, Teppanyaki... With the Robotagrill you will enjoy live cooking and will see how the chefs prepare their dishes around the grill... A real culinary show.

## COMBUSTION SHIELD MEASURES

## RECESSED INSTALLATION

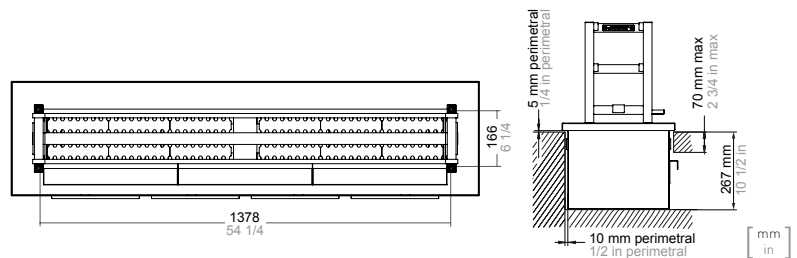

## ACCESSORIES INCLUDED

Skewer supports · Tongs · Temperature regulation grate · Grease tray



Ed.01.2021 - Josper reserves the right to make modifications to catalogues, pricelists and promotional material according to the development and improvements applied to its equipment.

# JOSPER ROBATAGRILL RGJ

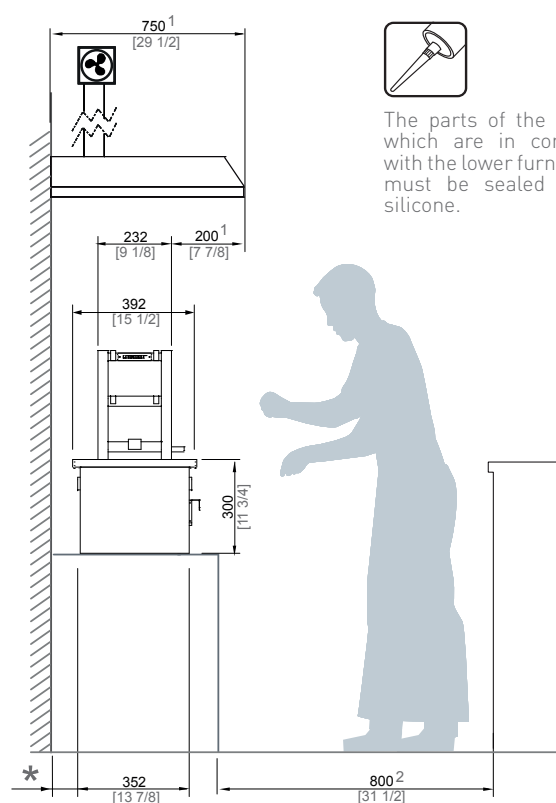
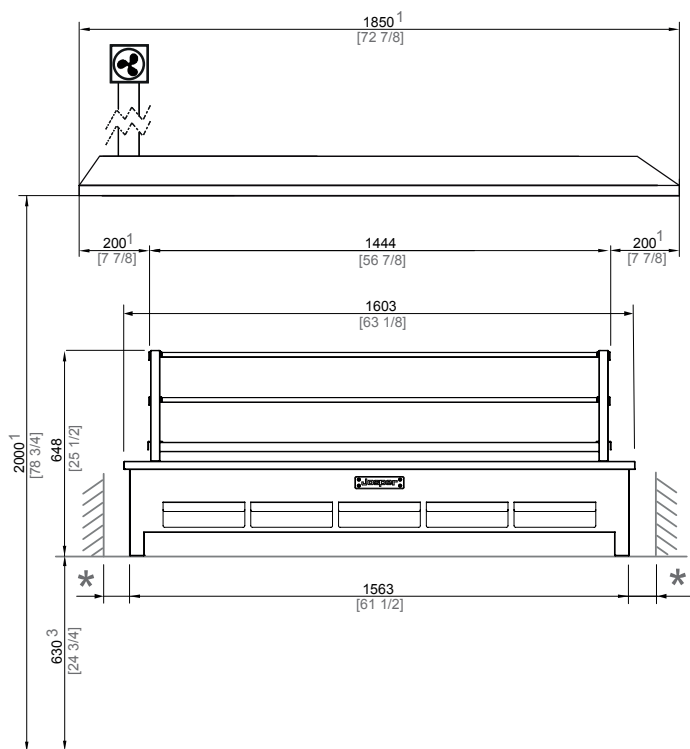
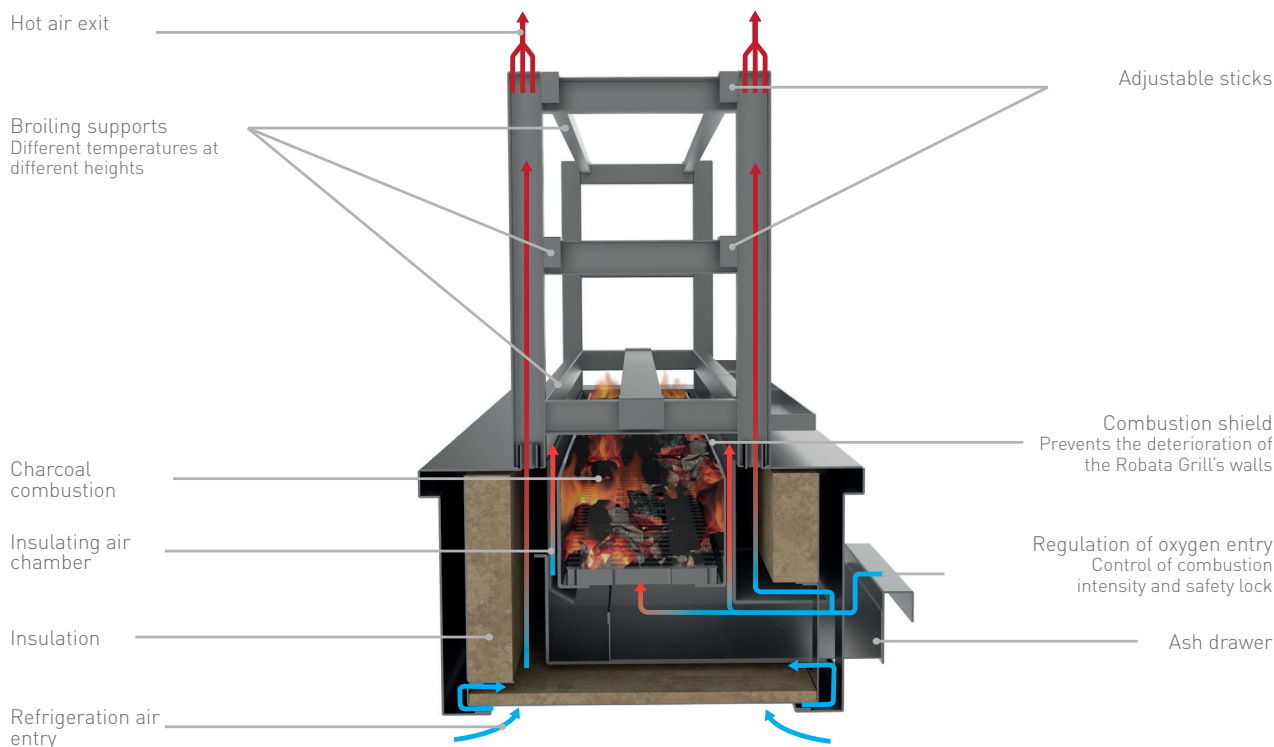

The parts of the oven which are in contact with the lower furniture must be sealed with silicone.

\* MINIMUM DISTANCE TO FLAMMABLE ELEMENTS: 300 mm [12 in] / RECOMMENDED DISTANCE TO ANOTHER ELEMENTS: 100 mm [4 in]

1 RECOMMENDED HOOD'S MINIMUM DIMENSIONS

2 RECOMMENDED CHEF'S WORKING SPACE

3 RECOMMENDED INSTALLATION HEIGHT

[ mm  
in ]

