

LA CIMBALI S30

LA CIMBALI

Bean-to-cup coffee machine up to 300 cups per day



La Cimbali S30 CS10



La Cimbali S30 CP10+TS4



Vitro Counter Fridge



Vitro Under-Counter Fridge

ITEM No. _____

Model options:

Semi-Automatic *'Barista-Serve'*

S30 CP10+TS4 (TS4 Steam Wand)

S30 CS10+TS4 (Steam Wand + Hot Chocolate)

Fully-Automatic *'Self-Serve'*

S30 CP11

S30 CS11 (Hot Chocolate)

(Fully automatic machines are without steam wand)

Milk fridge options:

VITRO COUNTER TOP (2x 4 pint)

VITRO UNDER-COUNTER (4x 4 pint)

(Milk fridge requires separate power supply)

Standard equipment:

PSSR safety certificate

Starter pack cleaning chemicals

Optional extras:

Water filter kit

Features:

La Cimbali knows just how important every drink is for you and your customers. That is why the S30 is designed to guarantee a wide and varied range to satisfy every palate, always with maximum quality guaranteed.

- **10.4-inch touch-screen** display allows you to see different options on the drinks menu (pre-selection and Group Mode) and to customise images displayed by the machine (such as screen savers and during beverage dispensing). You can also assist the customer when choosing their drink with video clips and animations.
- **TS4 TurboSteam Cold Touch** (Semi-Automatic ONLY) the outer surface of the wand is cold before, during and after it emits steam. The wand is coated with a special insulating, non-stick material. This makes the TS4 wand easy to clean and prevents milk residue from sticking to it.
- **AWS automatic washing system.** The daily washing cycles are automatically managed by the AWS system. This innovative system provides thorough, efficient cleaning, ensuring maximum hygiene with just one touch.
- **Hoppers and solubles** - Dual 1.5 kg bean hopper and built-in soluble chocolate system. (Chocolate only available on CS models)
- **Integrated bi-directional Wi-Fi system** - You can remotely communicate with the S30 via the integrated bidirectional Wi-Fi system, which makes updating software, setting recipes and customising background images simple and intuitive. (requires Wi-Fi connection at point of installation)
- **Titanium coated grinders** - The Titanium grinders, which are made of K110 steel with a PVD coating, are very robust and designed to last for a long time. Another innovation is the PGS (Perfect Grinding System), which continuously monitors the coffee delivery parameters and automatically re-grinds and doses if necessary, so as to ensure consistency in delivery and optimal extraction quality.

LA CIMBALI S30 - Bean-to-cup coffee machine up to 300 cups per day



Taylor UK
Catering Equipment Specialists

Taylor UK (a division of HTG Trading Ltd)

106 Claydon Business Park, Gt. Blakenham,
Ipswich, Suffolk, IP6 0NL, United Kingdom

0800 838 896 - sales@taylor-company.co.uk

www.taylor-company.co.uk

Due to continual research and development, these specifications are subject to change without notification.

June 2021

LA CIMBALI S30

LA CIMBALI

Bean-to-cup coffee machine up to 300 cups per day

ITEM No. _____

Section view - dimensions in mm (inches):

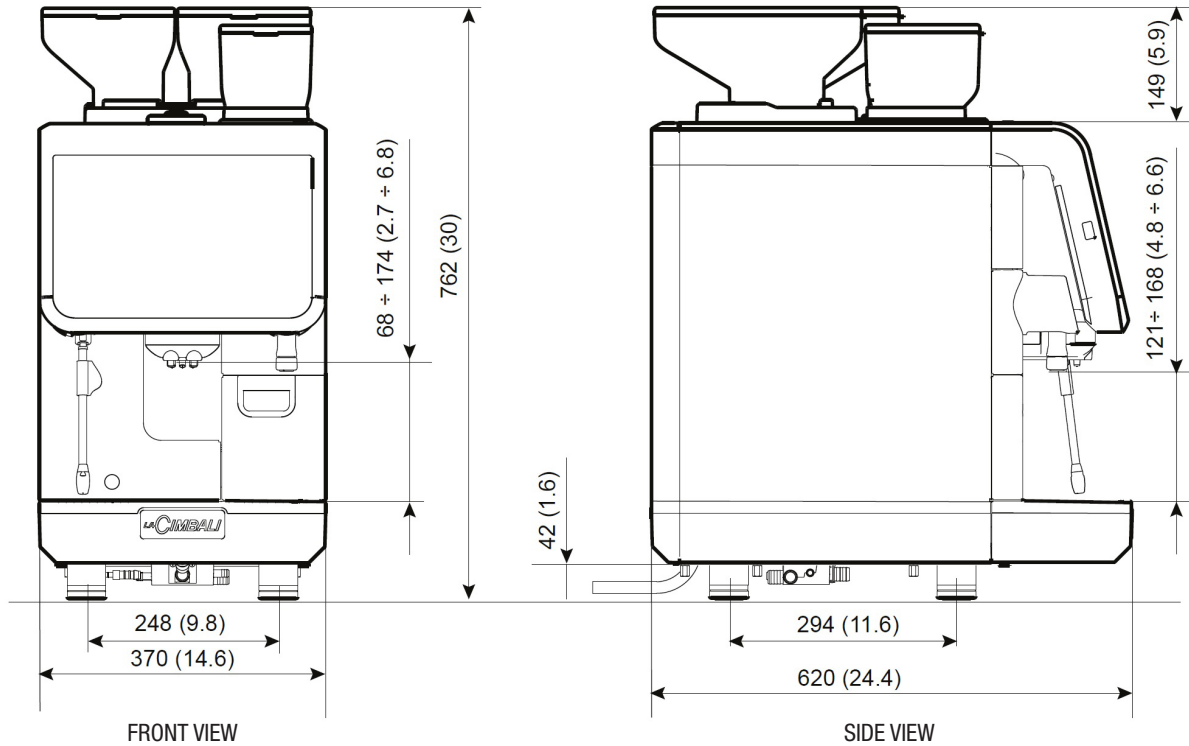

LA CIMBALI S30

	S30 CP10 + TS4	S30 CS10 + TS4	S30 CP11	S30 CS11
	Semi-Automatic - 'Barista Serve'		Fully Automatic - 'Self Serve'	
External dimensions (WxDxH)	370 x 620 x 762 mm			
Net weight	73 Kg (without milk fridge)			
Hot water / No. of selections	YES / 2			
Steam wand	YES - TS4	YES - TS4	NO	NO
Internal milk pump	YES (position of milk fridge, left side or below, must be specified at point of order)			
Coffee hoppers - No. / capacity	2 / 1.2 Kg ea			
Soluble chocolate hopper / capacity	NO	YES / 1.0 Kg	NO	YES / 1.0 Kg
Smart boiler - No. / capacity	2 / 0.7 litre ea			
Hot water + steam boiler capacity	1.25 litre			
Grinders	2 - Titanium coated with PSG system (auto adjustment)			
Connectivity	Bi-directional Wi-Fi + USB			
Water / waste connection*	2 Bar potable water (3/4" BSP shut off) / downpipe with U-bend (1-3/4")			
Voltage	230v / 50Hz / 1Ph			
Installed power	5,700 W			
Circuit breaker/fuse	32 amp			
Power socket	32 amp (1P+N+E)			

The external milk fridge requires it's own independent power supply (13amp plug socket - 5amp)

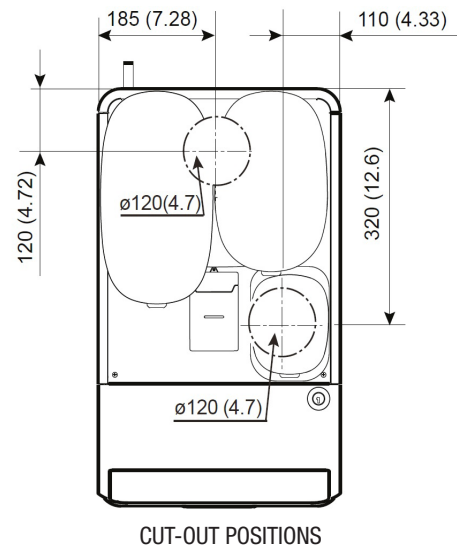

PLEASE NOTE: All counter cut-outs and utilities must be made and installed by the customer prior to delivery and installation.

*ALL La Cimballi coffee machines require a 2 Bar potable water supply (fitted with a suitable water filtration device) terminating in a 3/4" BSP shut-off valve and 1-3/4" waste downpipe with U-bend. Water and waste utilities must be located directly beneath the final position of the coffee machine.

Failure to have suitable utilities and counter cut-outs in place at point of installation may result in an aborted installation and will be chargeable.



Taylor UK
Catering Equipment Specialists

Taylor UK (a division of HTG Trading Ltd)
106 Claydon Business Park, Gt. Blakenham,
Ipswich, Suffolk, IP6 0NL, United Kingdom
0800 838 896 - sales@taylor-company.co.uk
www.taylor-company.co.uk

Due to continual research and development, these specifications are subject to change without notification.

June 2021

LA CIMBALI S30 - Bean-to-cup coffee machine up to 300 cups per day