

# FIT EXPRESS

**Prática**  
TECHNICOOK

## SINGLE MAGNETRON - Speed Oven

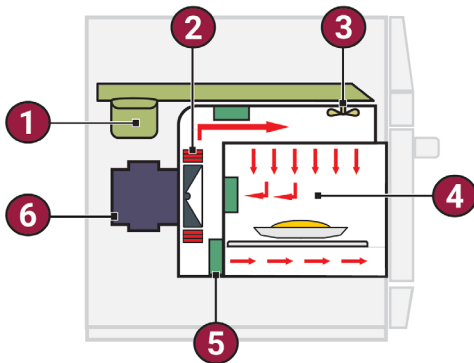

1. Magnetron x1
2. Impingement heater
3. Microwave stirrer
4. Impinged air
5. Catalytic converter
6. Blower motor

ITEM No. \_\_\_\_\_

### Model options:

- FIT EXPRESS SINGLE MAG - 13AMP (single phase)

### Standard equipment:

- 1x Paddle
- 1x Teflon tray
- 1x Baking rack
- 1x Oven guard protector spray
- 1x Non-caustic oven cleaner
- 1x Operators manual
- 12 Months parts and labour warranty

### Performance:

- FIT Express Single Mag (single magnetron) - Microwave power which is just right for fresh and chilled foods. With easy installation in places with limited electrical supply.
- FIT Express is the most compact speed oven with the largest capacity on the market. Its compact design allows it to occupy less space on the work counter.

### Features:

- Smallest Footprint in its category without sacrificing performance, consistency or quality
- Touch-screen display with intuitive and multi-language software, making it easy to set up, operate, and create recipes
- USB loading capabilities for programming and sharing settings between ovens
- Wi-Fi connectivity - upload new menus, add images to your oven remotely.
- Catalytic converter filter technology allows the oven to operate in any indoor area without the use of a hood
- Easy access to the removable catalytic converter that allows cleaning and maintenance to be performed by the end-user
- Manual cooking mode allows quick and intuitive cooking of unexpected menu items
- Independent controls of microwave power, temperature, and air speed
- Includes a daily cleaning function that cools the oven to safe temperatures and shows a video with recommended cleaning steps
- No side vents, allowing zero side clearance
- Up to 1024 recipes with 8 steps each in 16 groups
- Adjustable temperature from 30°C (86°F) to 280°C (536°F)
- Exterior, cool to the touch
- Stainless steel storage support rack on top

\*Ventless cooking operation supported with the exception of food classified as 'raw fatty proteins' such as, but not limited to, bone-in skin-on chicken, raw bacon, raw hamburger etc. Ultimate ventless operation is subject to local authority regulations and landlord permissions.



**Taylor UK**  
Catering Equipment Specialists

**Taylor UK** (a division of HTG Trading Ltd)  
106 Claydon Business Park, Gt. Blakenham,  
Ipswich, Suffolk, IP6 0NL, United Kingdom  
**0800 838 896 - sales@taylor-company.co.uk**  
**www.taylor-company.co.uk**

Due to continual research and development, these specifications are subject to change without notification - July 2022

**FIT EXPRESS - SINGLE MAGNETRON - Speed Oven**

# FIT EXPRESS

**Prática**  
TECHNICOOK

## SINGLE MAGNETRON - Speed Oven

ITEM No. \_\_\_\_\_

Section view:

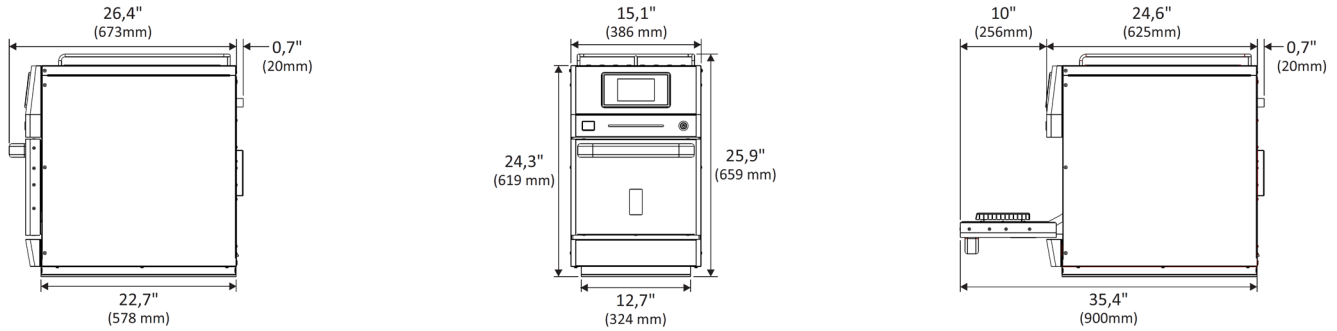

Installation:

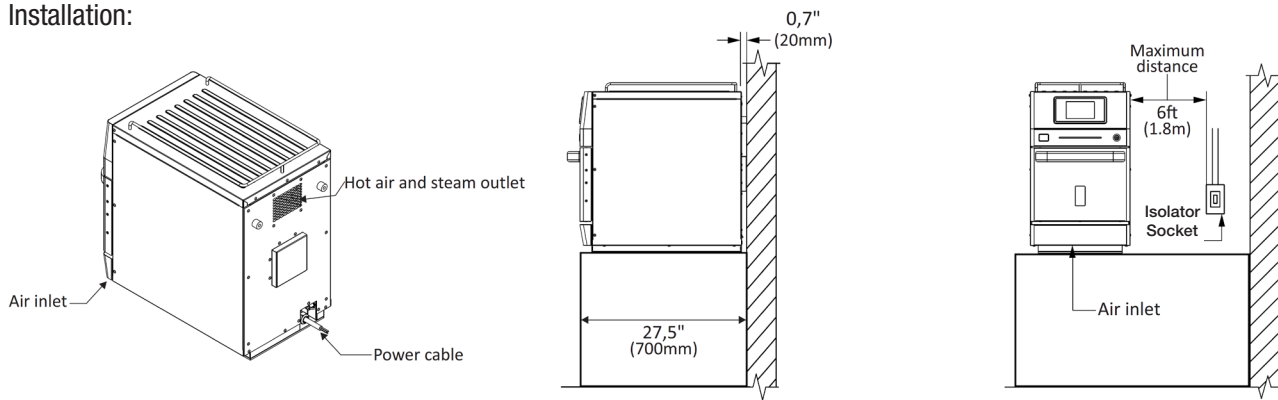

FIT EXPRESS	SINGLE MAG - 13amp
External OVEN dimensions (WxDxH)	386 x 673 x 659 mm
Crated dimensions (WxDxH)	550 x 900 x 820 mm
Net weight / crated weight	67 Kg / 86 Kg
Cook chamber volume	13.0 ltr
Cook chamber dimensions (WxDxH)	315 x 341 x 170 mm
Wall clearance (sides/rear)	25 mm / 25 mm
Voltage	230v / 50Hz / 1Ph
Nominal power	3.0 kW
Circuit breaker	13 amp
PRÁTICA RAPID COOK OVENS SHOULD BE INSTALLED WITH A D-TYPE CIRCUIT BREAKER	
Cable size	3 x 1.5 mm <sup>2</sup>
Isolator socket	13 amp (1P+N+E) 

- The oven must be installed on a base or counter that supports the weight of the unit (approx 70 kg).
- For proper ventilation, a minimum space of 1" (25mm) between the rear of the oven and the wall is required. The FIT Express is not designed for 'built-in' installation and requires suitable ventilation.
- Do not block the air inlets and exhaust outlets located on the bottom and rear of the oven.
- It is not recommended for the unit to be positioned near stoves, deep fryers, hot plates and other equipment that releases fat, fumes and heat.
- This unit must be properly grounded to avoid electrical shock. The FIT Express is equipped with a suitable plug. This plug must be connected to a properly installed and grounded outlet. In the event of an electrical short, properly grounding the unit reduces the risk of electrical shock by grounding the electrical current. The building electrical installation is the customer's responsibility.

**Improper installation may void the equipment warranty.**

FIT EXPRESS - SINGLE MAGNETRON - Speed Oven



**Taylor**<sub>UK</sub>  
Catering Equipment Specialists

**Taylor UK** (a division of HTG Trading Ltd)  
106 Claydon Business Park, Gt. Blakenham,  
Ipswich, Suffolk, IP6 0NL, United Kingdom  
**0800 838 896 - sales@taylor-company.co.uk**  
**www.taylor-company.co.uk**

Due to continual research and development, these specifications are subject to change without notification - July 2022