

# JOKER 6-23

with MT control, fresh steam system and water tank module



## HIGHLIGHTS

- MODULARITY  
Configuration options based on actual requirements
- CAPACITY  
Maximum use of space with minimum external dimensions, with a cavity 44 cm wide and 40 cm high
- FLEXIBILITY  
Selectable control position, based on available space
- DESIGN MODULE  
Form follows function.  
Clean lines, clear touch screen, simple operation

## JOKER 6-23 with MT control, fresh steam system and water tank module

### Device data

6-23	
Material	1.4301
Device dimensions	
Control on top, stop on the left / right (WxDxH) [mm]	520 x 625 x 805
Control on the right / stop on the left / right (WxDxH) [mm]	650 x 625 x 672
Weight [kg]	85
Weight, with packaging [kg]	101

6-23	
<b>Capacity</b>	
Number of inserts	5+1 x GN 2/3
Cavity volume [l]	65
Insert spacing [mm]	67

### Electrical connection

6-23	
<b>Voltage 200 V ... 230 V 1 NAC</b>	
Power requirement [kW]	3.6
Rated current [A]	15.7
Fuse protection	1 x 16 A
Residual-current circuit breaker	Type B 30
Tripping current [mA]	
Cable cross section (recommended) [mm <sup>2</sup> ]	1.5
<b>Voltage 380 V ... 415 V 3 NAC</b>	
Power requirement [kW]	5.8
Rated current [A]	8.4
Fuse protection	3 x 10 A
Residual-current circuit breaker	Type B 30
Tripping current [mA]	
Cable cross section (recommended) [mm <sup>2</sup> ]	1.5

### Heat output, heat emissions

Type	6-23
Heat, latent [MJ/h (kW)]	2.3 (0.6)
Heat, sensitive [MJ/h (kW)]	1.6 (0.4)
Noise [db (A)]	<70

### Setting up

Safety distance [mm]	rear	min. 50
	right	min. 50
	left	min. 50
Minimum clearance [mm]	to combi steamers, ovens, COMPACT PROs	min. 50
	to deep fryers, open/hot fat/oil, heat sources, gas appliances	min. 1000

### Water tanks

Fresh water tank	
Capacity [l]	6.5
Maximum operating time at 100% humidity [h]	1.5
Material	Stainless steel

Waste water tank	
Capacity [l]	5
Material	Stainless steel

Water quality	
General requirement:	Drinking water
Total hardness [°dh]	≤ 3
[ppm]	70 - 125
[°TH]	7 - 13
[°e]	5 - 9
pH value	7.0 - 8.5
Cl (chlorine) [mg/l]	max. 60
Cl <sub>2</sub> (free chlorine) [mg/l]	max. 0.2
SO <sub>4</sub> <sup>2-</sup> (sulphate) [mg/l]	max. 150
Fe (iron) [mg/l]	max. 0.1
Temperature [°C]	max. 40
electrical conductivity [µS/cm]	20 - 90

### Approvals, marks of conformity

Design module	as per DIN 18866-2
Manufacturer's certificate	CE conformity
Protection class	IPX5

## JOKER 6-23 with MT control, fresh steam system and water tank module

### Equipment

- 12 operating modes
- 7" capacitive screen
- USB interface
- Internal core temperature probe with 4 measuring points
- Supply air/exhaust air
- Frequency converter
- LED/triple glazing
- Quick-action door closure
- Adjustable air deflector
- Inner and outer housing made of rustproof stainless steel
- Seamless hygienic cooking chamber
- IPX 5 (resistant to water jets)

#### Start-Up Settings

##### Manual cooking / Manual baking

- Temperature, adjustable between 30°C - 300°C - to the exact degree
- Time, adjustable up to 24 hours, including continuous operation
- Core temperature, adjustable between 20°C - 100°C - to the exact degree
- Humidity can be exactly adjusted between 0 - 100%
- Steam injection, adjustable in ml or over time
- Automatic resting time in accordance with the steam injection quantity
- Manual humidification

- Steptronic®
- Step overview
- Alphanumeric memory function with image and sound selection
- Favourites marking during the saving process
- Menu group marking during the saving process
- Product group marking during the saving process
- Bar and product code marking during the saving process
- ADC - Active dehumidification in 5 stages
- Fan speed in 5 increments
- Timed fan speeds
- Preheat function with temperature specification, adjustable and adaptable
- E/2 Energy saving function
- SPS® - Steam Protection System
- Timer function: Input of start and end time
- Display of actual/target temperature
- Display of the actual core temperature

- Additional Cooking time
- Repeat mode
- Changing settings during operation
- Stop Preheat during operation

Half occupancy function

Last® 20

Programme list with 400 programs with 20 steps each:

- Program search
- Displaying and filtering menu groups
- Displaying and filtering product groups

Favourites list:

- Favourites search
- Displaying and filtering menu groups
- Displaying and filtering product groups

Special programs:

- Low-temperature cooking
- Delta-T cooking
- Regenerating
- Holding
- Thawing
- Proofing

Weekly programming PRO

Multi Cooking PRO

Cool Down function: Auto-Temp (default setting)

Cool Down function: Adjustable Manual-Temp

Cleaning & Care - manual cleaning supported

Settings & Service:

- Language setting in 25 languages
- Time and date setting
- Keyboard setting: 6 different versions
- Data and HACCP logging and display
- Automated cleaning and maintenance notices
- Automatic switching between standard time and daylight saving time
- Password manager
- Sound manager
- Image manager
- Program manager PRO
- Setting options
- Standby image and time setting
- Display setting: light or dark
- Start screen setting
- Setting and customisation options (Quick Modes/Direct Modes)
- Drying phase freely selectable

## JOKER 6-23 with MT module, fresh steam system and water tank module

### Additional module: Design module

- Unit back cover
- Unit colour
  - \* Minimum order quantity: 10 devices

### Device options

- Device feet
- Safety door latch
- Electric door latch
- External core temperature probe
- External sous vide probe
- LAN
- WLAN
- Energy optimization connection
- Connection of potential-free contact to control third-party appliances (e.g. external extractor hoods)

### Accessories

- Multi-Eco condensation hood
- Kombimix kits, base frames and Multi-Eco condensation hoods for Mix stations
- Various racks
- Base frames
- Various trays, grills and containers
- ProConnect

**JOKER 6-23 with MT module, fresh steam system and water tank module**

**Dimensioned drawing 6-23, door stop on the left, control on top**

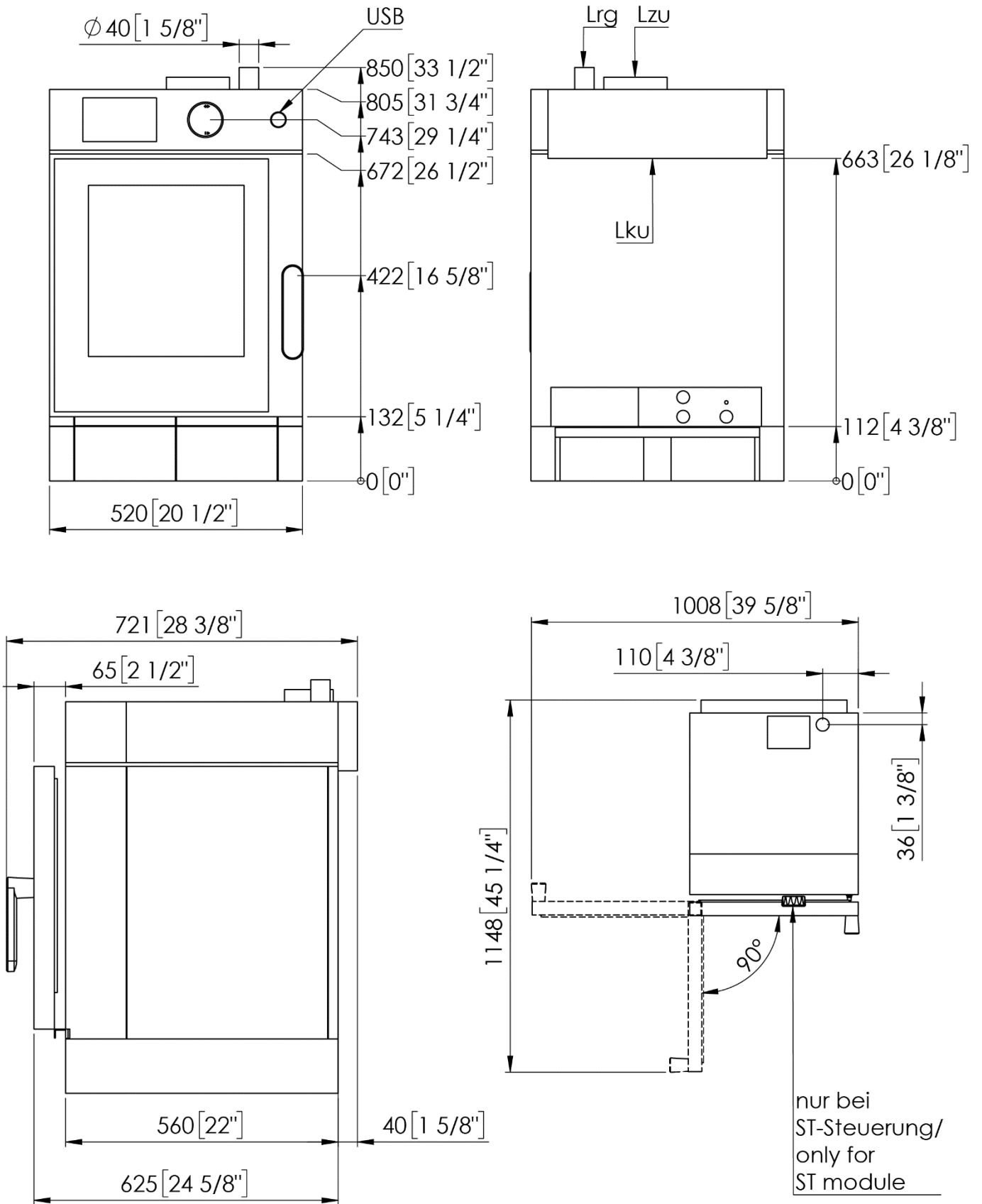

nur bei  
ST-Steuerung/  
only for  
ST module

- Lzu Zuluftöffnung / Supply air opening
- Lku Luftansaugschacht Gerätekühlung/  
Air intake for cooling
- Lrg Abluffrohr / Exhaust air pipe
- USB USB-Buchse / USB port

**JOKER 6-23 with MT module, fresh steam system and water tank module**

**Dimensioned drawing 6-23, door stop on the left, control on the right**

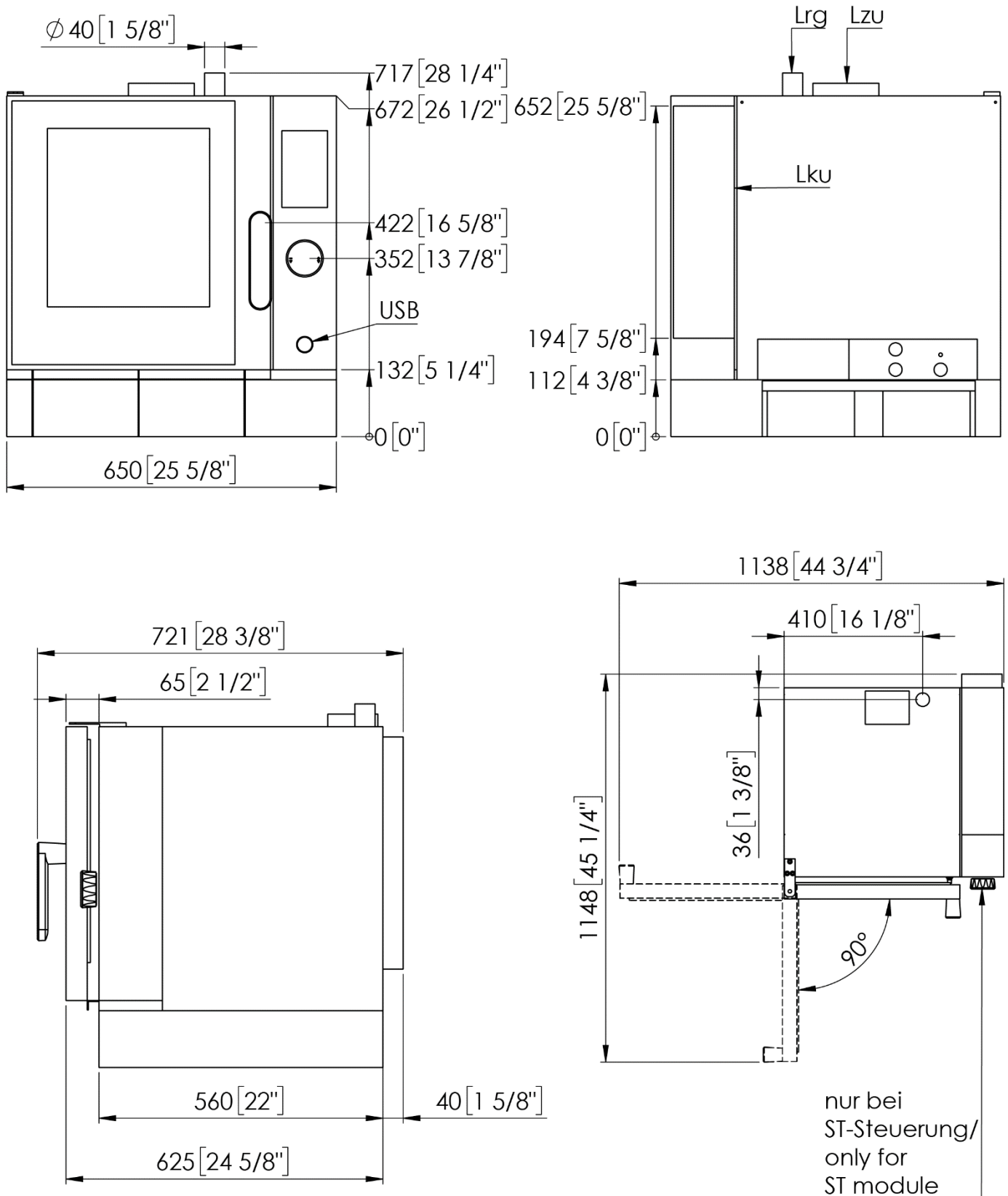

- Lzu Zuluftöffnung / Supply air opening
- Lku Luftansaugschacht Geräte Kühlung /  
Air intake for cooling
- Lrg Abluftrohr / Exhaust air pipe
- USB USB-Buchse / USB port

**JOKER 6-23 with MT module, fresh steam system and water tank module**

**Dimensioned drawing 6-23, door stop on the right, control on top**

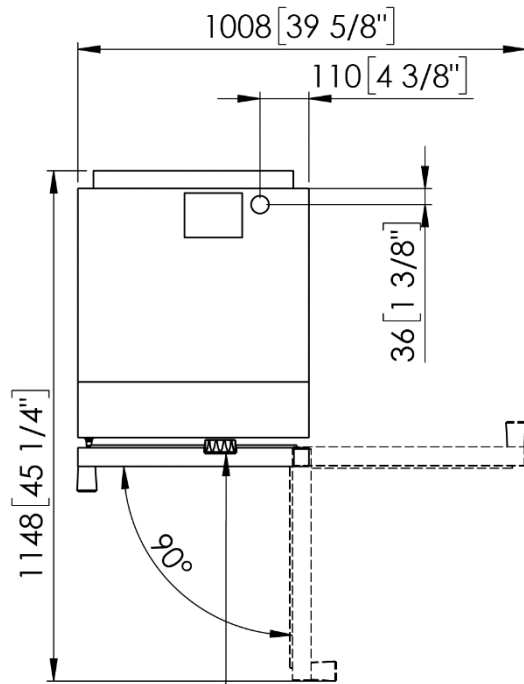
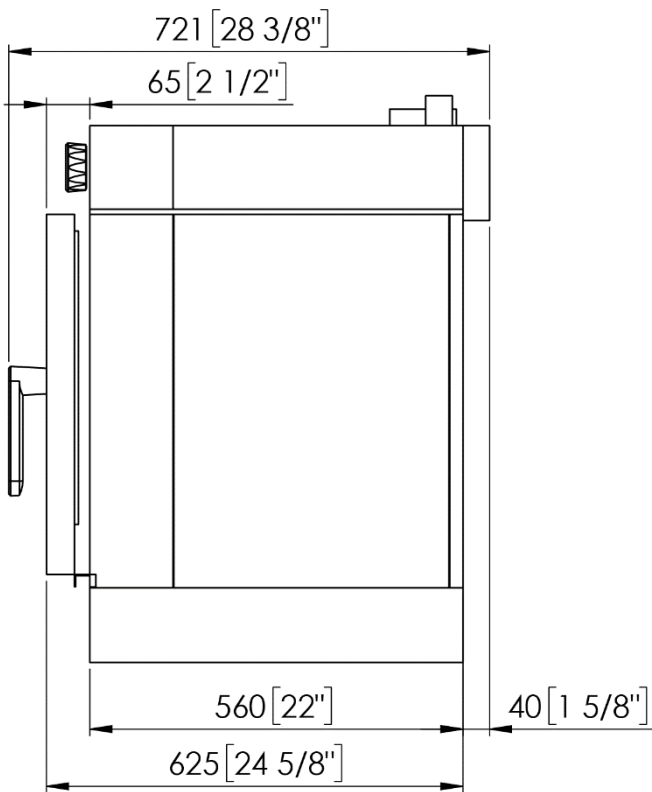
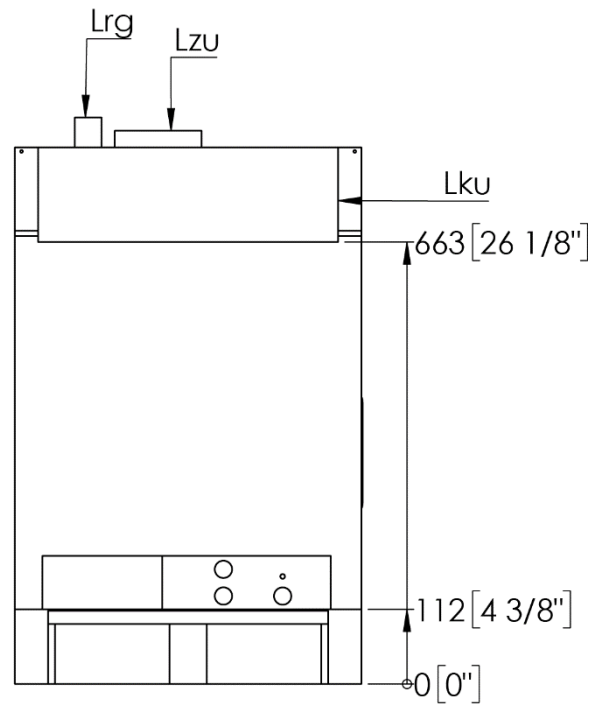
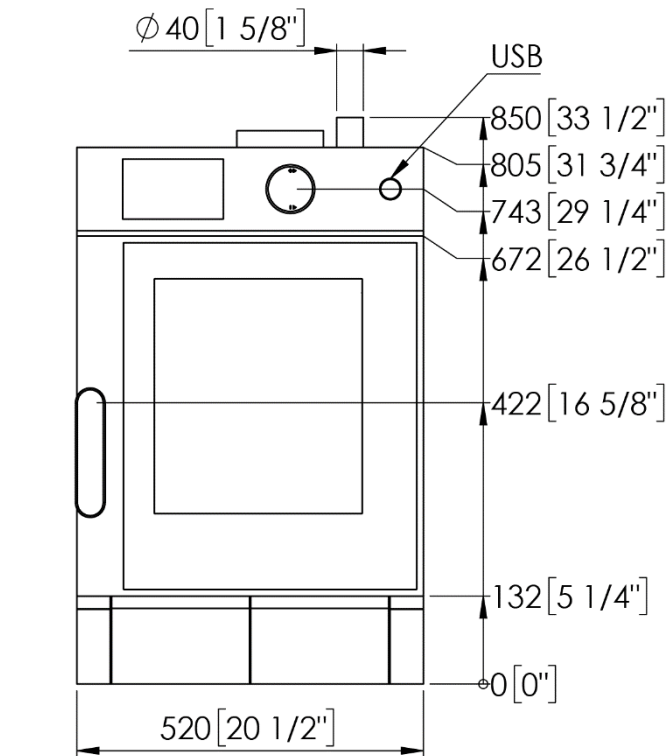

nur bei  
ST-Steuerung/  
only for  
ST module

- Lzu Zuluftöffnung / Supply air opening
- Lku Luftansaugschacht Gerätekühlung/  
Air intake for cooling
- Lrg Abluftrohr / Exhaust air pipe
- USB USB-Buchse / USB port





## JOKER 6-23 with MT module, fresh steam system and water tank module

### Connection diagram

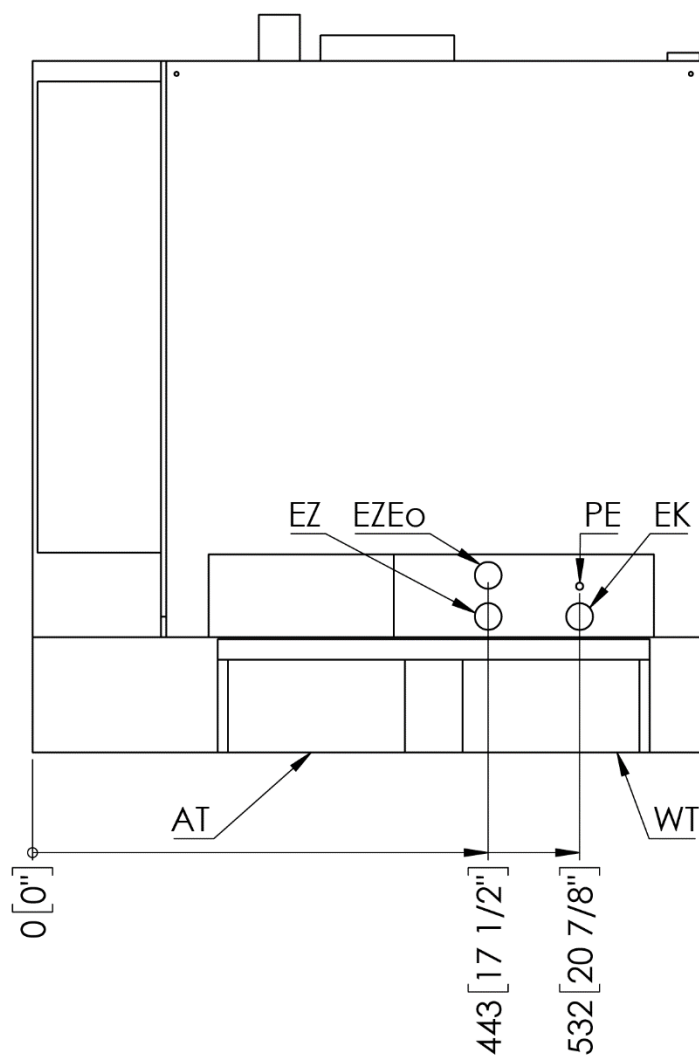
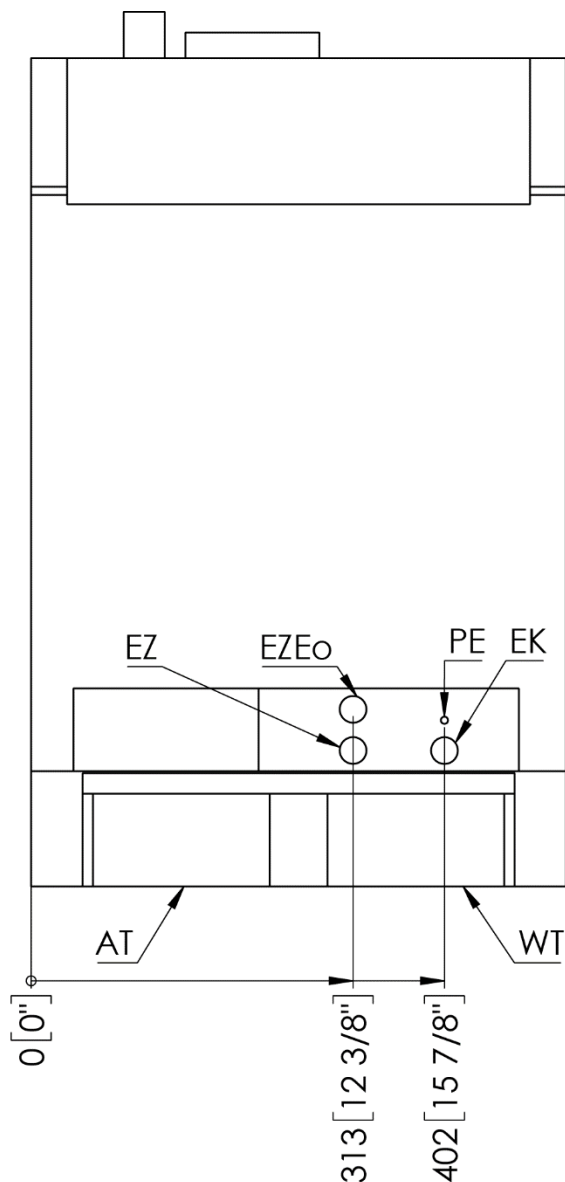

Die Maße entsprechen auch der Variante mit Steuerung Seite (links)/

The dimensions also correspond to the variant with control on the left side

- AT Abwassertank  
Waste water tank
- EK Kommunikationsanschluss (z.B. RS232, LAN)  
Communications connection (e.g. RS232, LAN)
- EWk Anschluss Weichwasser  
Connection for soft water
- EZ Stromversorgung  
Power supply

- EZEo Optimierungsanlage  
Power optimization
- PE Anschluss Potenzialausgleich  
Connection for potential equalisation
- WT Frischwassertank  
Fresh water tank



Taylor UK  
(A division of HTG Trading Ltd)  
106 Claydon Business Park  
Gt. Blakenham, Ipswich  
IP6 0NL

## EQUIPMENT SALES

---

0800 838 896  
sales@taylor-company.co.uk  
www.taylor-company.co.uk

## TECHNICAL SERVICE

---

01473 350000  
service@htgradng.co.uk



Eloma GmbH • Otto-Hahn-Str. 10 • 82216 Maisach/Germany  
T. +49 8141 395-0 • F. +49 8141 395-130 • sales@eloma.com  
eloma.com

an Ali Group Company



The Spirit of Excellence