

# ISI-161TH

Compact Soft Serve Freezer - Single Flavour, Gravity  
HEAT TREATMENT

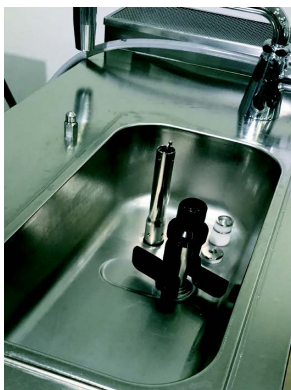

ISI-161TH Panel Air Filter



ISI-161TH with optional hopper agitator



ITEM No. \_\_\_\_\_

Model options:

ISI-161TH/1A Compact Soft Serve Freezer

Standard equipment:

- 1x Starter kit sanitiser sachets
- 1x Cleaning Kit
- 1x Tube food safe lubricant
- 1x Replacement tune up kit
- 12 Months parts & labour warranty

Optional extras:

- Hopper agitator
- Extended service contract (call for details)

## Features:

Compact slimline counter top soft serve freezer. Ideal for businesses looking to add a soft serve product to their menu offer. Perfect for dairy based soft ice cream or plant based products.

- **Freezing Cylinder** - One, 1.4 litre
- **Hourly Production\*\*** - 12 Kg (approximately)
- **Mix Hopper** - One, 3.0 litre. Maintains the temperature of mix, under 5°C in Auto & Standby modes. (Hopper agitator available by special order)
- **Direct Motor Drive** - Less noise & Less vibration
- **Heat Treatment System (Pasteurisation)** - Pasteurisation involves heating dairy products for a period of time to kill bacteria, maintaining dairy products up to two weeks. You can also choose an automatic or manual pasteurisation system.
- **Artificial Intelligence Control System** - A.I Control System makes high quality soft serve ice cream.
- **Standby** - During long no-use periods, the standby feature maintains safe product temperatures in the mix hopper and freezing cylinder.
- **Slim & Compact Design** - Excellent space utilisation. The mini sized machine is perfect for space limited businesses.
- **Rinse Shower** - Built-in flexible rinse shower makes cleaning easy.



**Taylor UK**  
Catering Equipment Specialists

**Taylor UK** (a division of HTG Trading Ltd)  
106 Claydon Business Park, Gt. Blakenham,  
Ipswich, Suffolk, IP6 0NL, United Kingdom  
0800 838 896 - [sales@taylor-company.co.uk](mailto:sales@taylor-company.co.uk)  
[www.taylor-company.co.uk](http://www.taylor-company.co.uk)

Due to continual research and development, these specifications are subject to change without notification - June 2023

ISI-161TH - Compact Soft Serve Freezer - Single Flavour, Gravity, HEAT TREATMENT

# ISI-161TH



ITEM No. \_\_\_\_\_

## Compact Soft Serve Freezer - Single flavour, gravity HEAT TREATMENT

Section view: (Dimensions shown in brackets in inches)

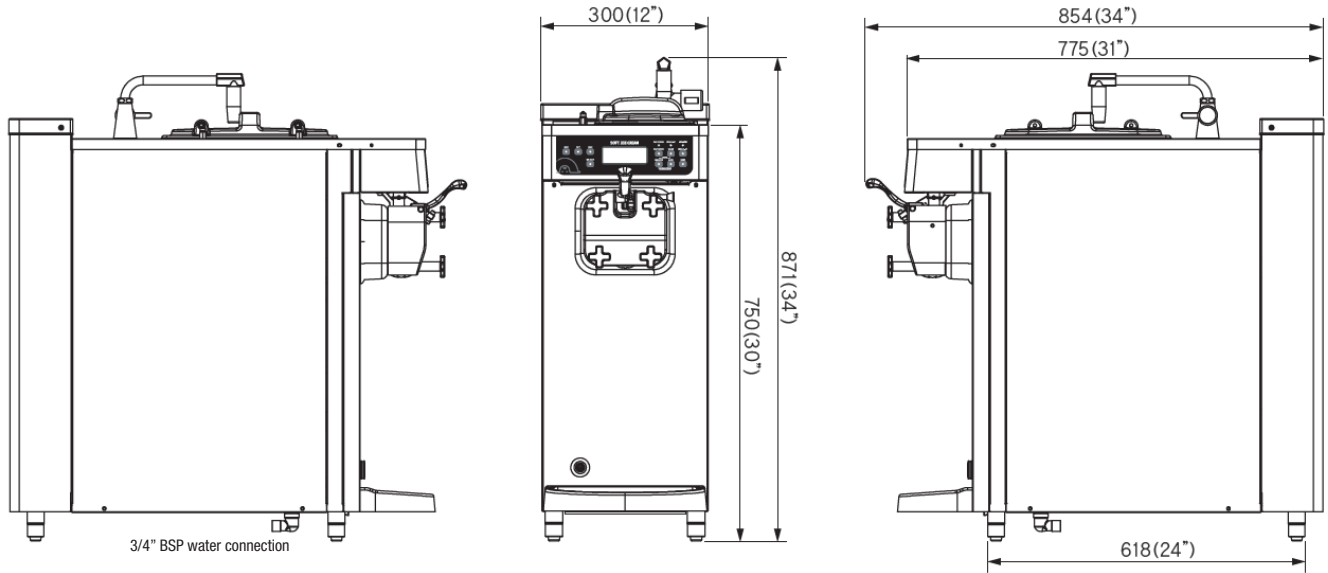

Icetro ISI-161TH	SINGLE PHASE
External dimensions (WxDxH)	300 x 854 x 871 mm
Net weight / crated weight (freezer only)	89 Kg / 108 Kg
Wall clearance* (sides/back)	25 mm / 25 mm
Soft serve freezers are NOT designed for built-in installation	
Refrigeration	R452a
Beater motor	0.35 Kw
Cooling	Air ONLY
Approximate hourly production**	12 Kg
Water connection - rinse shower	3/4" BSP - Potable
Power consumption	1,400 w
Voltage	230v / 50Hz / 1Ph
Total amp draw	6.1 amps
Circuit breaker/fuse	13 amp
Isolator socket	13 amp (1P+N+E)



\*Minimum air clearances **MUST** be met to assure adequate airflow for optimum performance of air cooled machines. Place the back of the unit against a wall to prevent recirculation of warm air.

\*\*Hourly production figures are approximate and based on optimum operating conditions. Product type, ambient air temperature and air flow will effect the production capacity.

• A dedicated power supply is required within 1m for safe operation. Icetro equipment should never be operated on any form of extension lead, please consult a qualified electrician for correct installation advice.



**Taylor** UK  
Catering Equipment Specialists

**Taylor UK** (a division of HTG Trading Ltd)  
106 Claydon Business Park, Gt. Blakenham,  
Ipswich, Suffolk, IP6 0NL, United Kingdom  
0800 838 896 - sales@taylor-company.co.uk  
www.taylor-company.co.uk

Due to continual research and development, these specifications are subject to change without notification - June 2023