

342

Twin Flavour Frozen Beverage Freezer



Taylor 342 shown with optional panel spinners



ITEM No. _____

Model options:

342/1A Twin Beverage Freezer (single phase)

(AIR cooled as standard)

Standard equipment:

- 1x Refrigerated syrup rail
- 1x Starter kit sanitiser sachets
- 1x White cleaning bucket
- 1x Tube Taylor food safe lubricant
- 1x Set Taylor cleaning brushes
- 1x Replacement tune up kit
- 12 Months parts & labour warranty

Optional extras:

- Panel moulder spinner blenders (x2)
- Extended service contract (call for details)

Features:

High capacity unit designed for consistent volume production of frozen slush, milkshakes, iced cappuccino and smoothies.

- ♦ **Freezing Cylinder** - Two, 6.6 litre
- ♦ **Hourly Production**** - 109.0 litres (combined output, approximately)
- ♦ **Mix Hopper** - Two, 18.9 litre. Refrigerated to maintain mix below 5°C.
- ♦ **Indicator Lights** - Add Mix light and audible alarm alerts the operator to add mix. When the Mix Out light flashes, the unit automatically shuts down to prevent damage.
Upon spinner actuation, the spinner light illuminates for 15 seconds as a visual indicator of recommended blending time (only if panel spinner option has been specified).
- ♦ **Automatic Consistency Control** - A specially designed viscosity control automatically maintains superior product quality.
- ♦ **Freezer Door** - Purge port for quick priming, clear plastic doors merchandises the product while it's freezing.
- ♦ **Panel Spinners** - Conveniently mounted on both sides of the freezer for blending syrups and small inclusions into your beverages.
(Optional extra)
- ♦ **Syrup Rail** - The integral syrup rail allows flavours to be stored in the recessed area below the dispensing spouts. Separate refrigeration system maintains food safe product temperatures.
Please note - the syrup rail is not designed to hold dairy products.



TaylorUK
Catering Equipment Specialists

Taylor UK (a division of HTG Trading Ltd)
106 Claydon Business Park, Gt. Blakenham,
Ipswich, Suffolk, IP6 0NL, United Kingdom
0800 838 896 - sales@taylor-company.co.uk
www.taylor-company.co.uk

Due to continual research and development, these specifications are subject to change without notification - July 2023

342



ITEM No. _____

Twin Flavour Frozen Beverage Freezer

Section view: (Dimensions shown in brackets in mm)

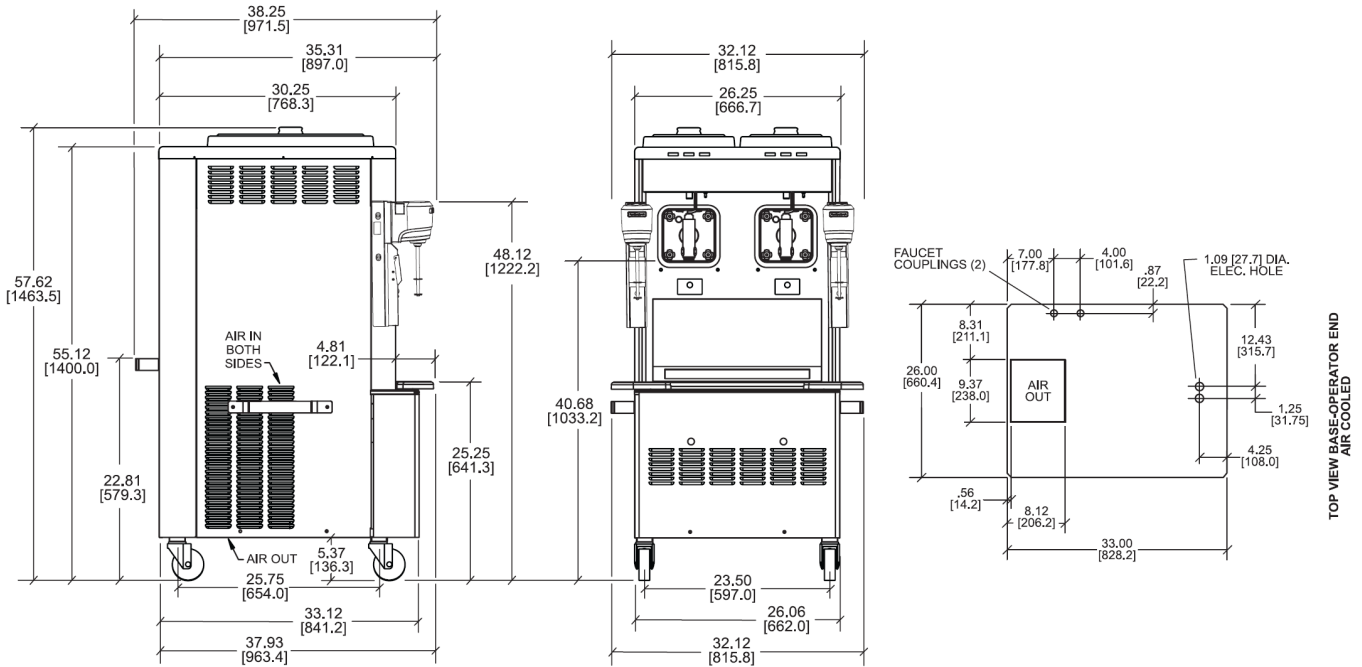

Taylor 342	SINGLE PHASE
External dimensions (WxDxH)	816 x 972 x 1464 mm
Net weight / crated weight (freezer only)	235.4 Kg / 269 Kg
Wall clearance* (sides/back)	76 mm / 76 mm
Soft serve & shake freezers are NOT designed for built-in installation	
Refrigeration system	2x 7,500 BTU/hr - R449A
Beater motor (No./Power)	2 - 0.5 HP
Cooling	Air
Approximate hourly production**	109.0 ltr
Voltage	230v / 50Hz / 1Ph
Minimum amp draw	14 (left) 10 (right) amps
Circuit breaker	2x 16 amp
Isolator socket	2x 16amp (1P+N+E)
	2X 

*Minimum air clearances **MUST** be met to assure adequate airflow for optimum performance of air cooled machines. Install the deflector provided and place the back of the unit against a wall to prevent recirculation of warm air.
 **Hourly production figures are approximate and based on optimum operating conditions. Product type, ambient air temperature and air flow will effect the production capacity.
 •Two dedicated power supplies are required for safe operation. Taylor equipment should never be operated on any form of extension lead, please consult a qualified electrician for correct installation advice.

Data for air cooled units.



Taylor UK (a division of HTG Trading Ltd)
 106 Claydon Business Park, Gt. Blakenham,
 Ipswich, Suffolk, IP6 0NL, United Kingdom
0800 838 896 - sales@taylor-company.co.uk
www.taylor-company.co.uk

Due to continual research and development, these specifications are subject to change without notification - July 2023