

ISI-163TTH

Soft Serve Freezer - Twin Flavour, Gravity
HEAT TREATMENT

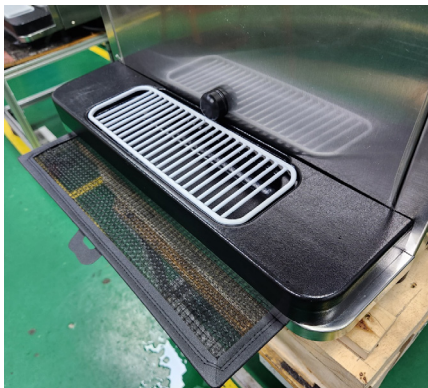

ISI-163TTH Bottom Panel Air Filter



ISI-163TTH Hopper Agitator & Feed Tube

ITEM No. _____

Model options:

ISI-163TTH/1A Twin Soft Serve Freezer, Gravity

Standard equipment:

- 1x Starter kit sanitiser sachets
- 1x Cleaning Kit
- 1x Tube food safe lubricant
- 1x Replacement tune up kit
- 12 Months parts & labour warranty

Optional extras:

Extended service contract (call for details)

Features:

Counter top soft serve freezer. Ideal for businesses looking to add two different flavours or two different soft serve products to their menu offer. The middle handle 'twists' the two options together. Perfect for dairy based soft ice cream or plant based products.

- **Freezing Cylinder** - Two, 1.6 litre
- **Hourly Production**** - 24 Kg (approximately)
- **Mix Hopper** - Two, 12.5 litre. Maintains the temperature of mix, under 5°C in Auto & Standby modes. Agitator circulates the ice cream mix to prevent separation and to ensure even temperature distribution. Mix low and mix out warnings operate automatically preventing damage to the machine.
- **Direct Motor Drive** - Less noise & Less vibration
- **Heat Treatment System** (Pasteurisation) - Pasteurisation involves heating dairy products for a period of time to kill bacteria, maintaining dairy products up to two weeks. You can also choose an automatic or manual pasteurisation system.
- **Artificial Intelligence Control System** - A.I Control System makes high quality soft serve ice cream.
- **Standby** - During long no-use periods, the standby feature maintains safe product temperatures in the mix hopper and freezing cylinder.
- **Additional Functions** - defrost, product regeneration and water heating functions for easier cleaning.



Taylor UK
Catering Equipment Specialists

Taylor UK (a division of HTG Trading Ltd)
106 Claydon Business Park, Gt. Blakenham,
Ipswich, Suffolk, IP6 0NL, United Kingdom
0800 838 896 - sales@taylor-company.co.uk
www.taylor-company.co.uk

Due to continual research and development, these specifications are subject to change without notification - June 2025

ISI-163TTH



ITEM No. _____

Soft Serve Freezer - Twin Flavour, Gravity HEAT TREATMENT

Section view: (Dimensions shown in brackets in inches)

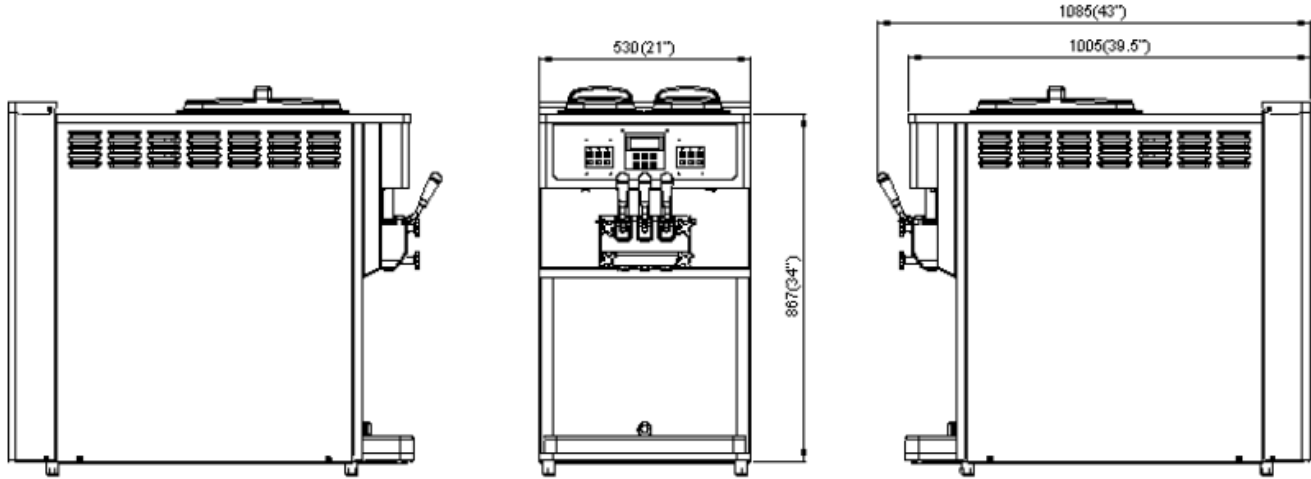

Icetro ISI-163TTH	SINGLE PHASE
External dimensions (WxDxH)	530 x 1005 x 867 mm
Net weight / crated weight (freezer only)	250 Kg / 280 Kg
Wall clearance* (sides/back)	100 mm / 25 mm
Soft serve freezers are NOT designed for built-in installation	
Refrigeration	R449a
Beater motor	0.37 Kw
Cooling	Air ONLY
Approximate hourly production**	24 Kg
Power consumption	2,850 w
Voltage	230v / 50Hz / 1Ph
Total amp draw	12.4 amps
Circuit breaker/fuse	16 amp
Isolator socket	16 amp (1P+N+E) 

*Minimum air clearances **MUST** be met to assure adequate airflow for optimum performance of air cooled machines. Place the back of the unit against a wall to prevent recirculation of warm air.

**Hourly production figures are approximate and based on optimum operating conditions. Product type, ambient air temperature and air flow will effect the production capacity.

• A dedicated power supply is required within 1m for safe operation. Icetro equipment should never be operated on any form of extension lead, please consult a qualified electrician for correct installation advice.



TaylorUK
Catering Equipment Specialists

Taylor UK (a division of HTG Trading Ltd)
106 Claydon Business Park, Gt. Blakenham,
Ipswich, Suffolk, IP6 0NL, United Kingdom
0800 838 896 - sales@taylor-company.co.uk
www.taylor-company.co.uk

Due to continual research and development, these specifications are subject to change without notification - June 2025